

Service Manual

PIONEER®
The Art of Entertainment

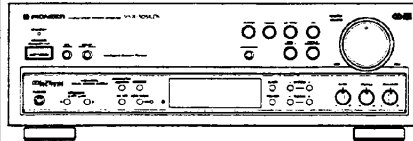

ORDER NO.
RRV1538

AUDIO/VIDEO STEREO RECEIVER

VSX-505RDS

VSX-405RDS

THIS MANUAL IS APPLICABLE TO THE FOLLOWING MODEL(S) AND TYPE(S).

Type	Model		Power Requirement	Remarks
	VSX-505RDS	VSX-405RDS		
HVXX		○	AC230V	
HYXX/EW		○	AC220-230V	
HYXX/GR		○	AC220-230V	

CONTENTS

1. DISASSEMBLY	2
2. EXPLODED VIEWS, PACKING AND PARTS LIST	4
3. BLOCK DIAGRAM	10
4. SCHEMATIC AND PCB CONNECTION DIAGRAMS	11
5. PCB PARTS LIST	35
6. ADJUSTMENTS	40
7. IC INFORMATION	42
8. FL INFORMATION	44
9. REMOTE CONTROL UNIT [CU-VSX106 (AXD7087)] (VSX-505RDS ONLY)	45
10. PANEL FACILITIES	50
11. SPECIFICATIONS	52

PIONEER ELECTRONIC CORPORATION 4-1, Meguro 1-Chome, Meguro-ku, Tokyo 153, Japan

PIONEER ELECTRONIC SERVICE, INC. P.O. Box 1760, Long Beach, CA 90801-1760, U. S. A.

PIONEER ELECTRONIC (EUROPE) N.V. Haven 1087 Keetberglaan 1, 9120 Melsele, Belgium

PIONEER ELECTRONICS ASIACENTRE PTE. LTD. 501 Orchard Road, #10-00 Lane Crawford Place, Singapore 0923

© PIONEER ELECTRONIC CORPORATION 1996

T-SSG APR. 1996 Printed in Japan

VSX-505RDS, VSX-405RDS

1. DISASSEMBLY

CAUTION !

You will get an electric shock if you touch the Radiator (Heat-sink) when the power cord is connected to the power source. Also, the Electrolytic Capacitor contains a charge even when the power cord is unplugged, so the charge must be removed when the bonnet has been taken off.

< Removing the Charge >

- ① Connect the Radiator (top side) and either the Chassis or the Rear panel for 2 to 3 seconds with a Resistor of more than $5W/10\Omega$.
- ② Connect the +B lead on the J2 and either the Chassis or the Rear panel for 2 to 3 seconds with a Resistor of more than $5W/10\Omega$.

■ BONNET

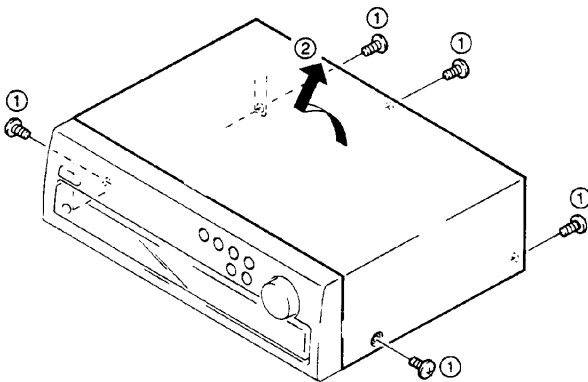

■ AMP ASSY

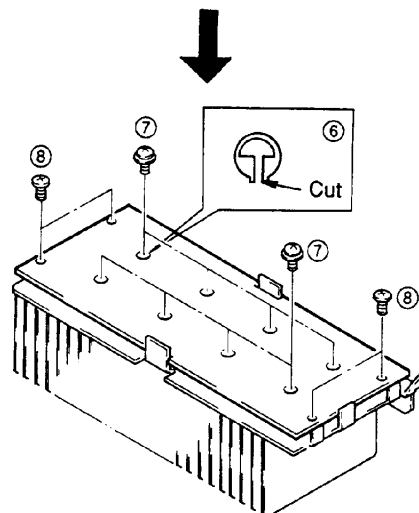
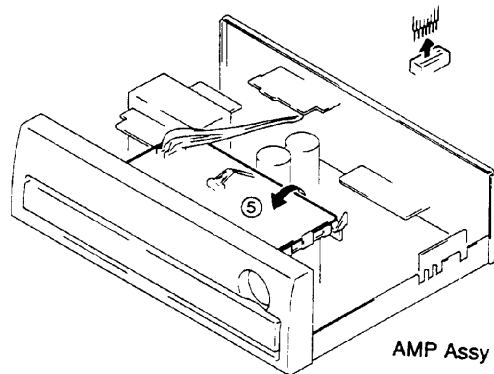
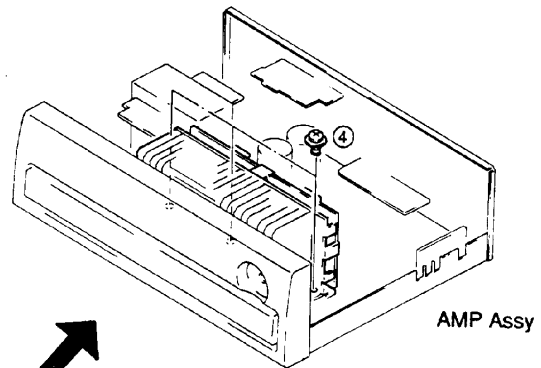
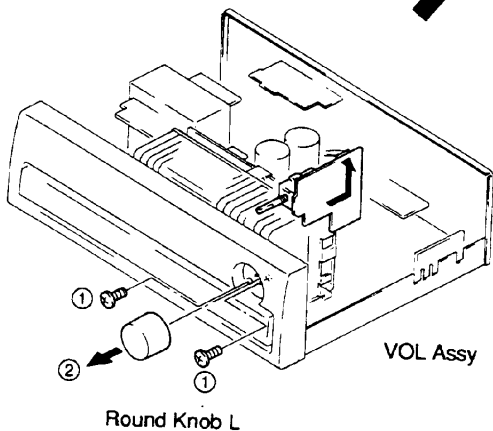

VSX-505RDS, VSX-405RDS

■ MOTHER ASSY

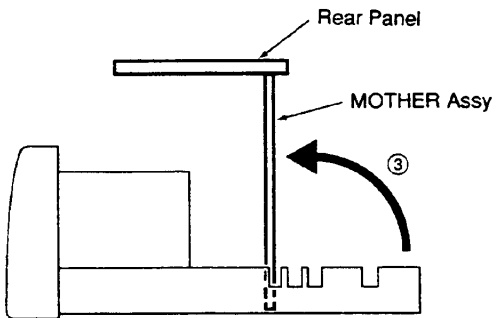
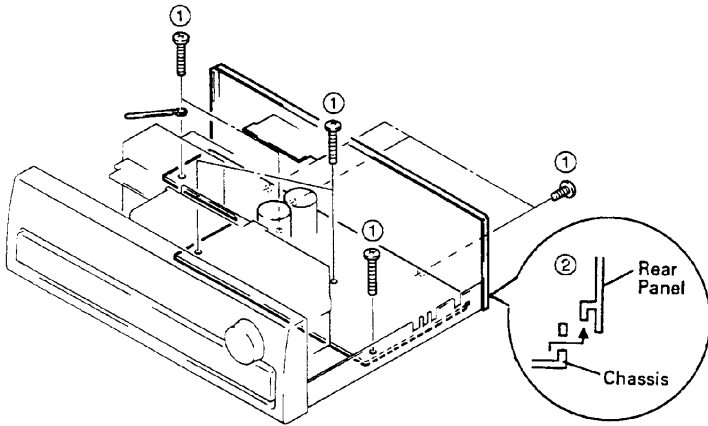

■ FL AND UCOM ASSY

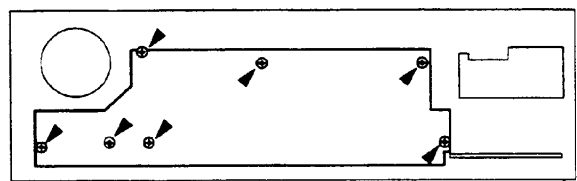
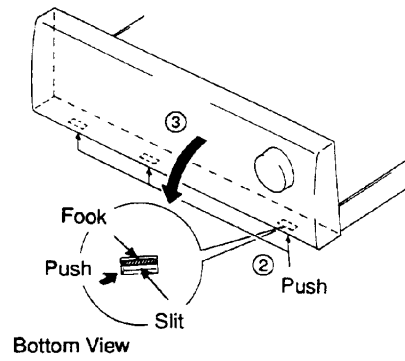
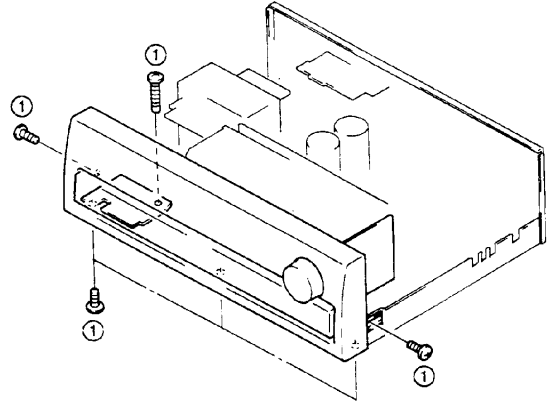

Front Panel Section

VSX-505RDS, VSX-405RDS

2. EXPLODED VIEWS, PACKING AND PARTS LIST

NOTES:

- Parts marked by "NSP" are generally unavailable because they are not in our Master Spare Parts List.
- The Δ mark found on some component parts indicates the importance of the safety factor of the parts. Therefore, when replacing, be sure to use parts of identical designation.
- Parts marked by "⊙" are not always kept in stock. Their delivery time may be longer than usual or they may be unavailable.

2.1 PACKING

■ CONTRAST OF VSX-505RDS/HVXK, HVXK/EW, HVXK/GR, VSX-405RDS/HVXK, HVXK/EW AND HVXK/GR

VSX-505RDS/HVXK, HVXK/EW, HVXK/GR, VSX-405RDS/HVXK, HVXK/EW and HVXK/GR have the same construction except for the following:

Mark	No.	Symbol & Description	Part No.						Remarks
			VSX-505RDS			VSX-405RDS			
			HVXK	HVXK/EW	HVXK/GR	HVXK	HVXK/EW	HVXK/GR	
	4	Packing case	AHD7273	AHD7273	AHD7273	AHD7264	AHD7264	AHD7264	
	5	Operating instructions (English)	ARB7069	Not Used	Not Used	ARB7079	Not Used	Not Used	
	5	Operating instructions (Dutch/Swedish/Spanish/Portuguese)	Not Used	ARC7107	Not Used	Not Used	ARC7124	Not Used	
	5	Operating instructions (English/French/German/Italian)	Not Used	ARE7063	Not Used	Not Used	ARE7076	Not Used	
	5	Operating instructions (German)	Not Used	Not Used	ARC7108	Not Used	Not Used	ARC7108	
NSP	6	Battery (LR6P, AA)	AEX1007	AEX1007	AEX1007	Not Used	Not Used	Not Used	
NSP	6	Battery (R6P, AA)	Not Used	Not Used	Not Used	VEM-013	VEM-013	VEM-013	
	9	Remote control unit (CU-VSX106)	AXD7087	AXD7087	AXD7087	Not Used	Not Used	Not Used	
	9	Remote control unit (CU-VSX107)	Not Used	Not Used	Not Used	AXD7084	AXD7084	AXD7084	
	11	Battery cover	Not Used	Not Used	Not Used	AZA7123	AZA7123	AZA7123	

■ PARTS LIST FOR VSX-505RDS/HVXK

Mark	No.	Description	Part No.
	1	Packing sheet	AHG7028
	2	Front pad	AHA7115
	3	Rear pad	AHA7116
	4	Packing case	AHD7273
	5	Operating instructions (English)	ARB7069
NSP	6	Battery (LR6, AA)	AEX1007
	7	FM antenna assy	ADH7002
	8	Loop antenna assy	ADH7006
	9	Remote control unit (CU-VSX106)	AXD7087
	10	
	11	
NSP	12	Serial sheet	AAX1523
NSP	13	Warranty card	ARY7010

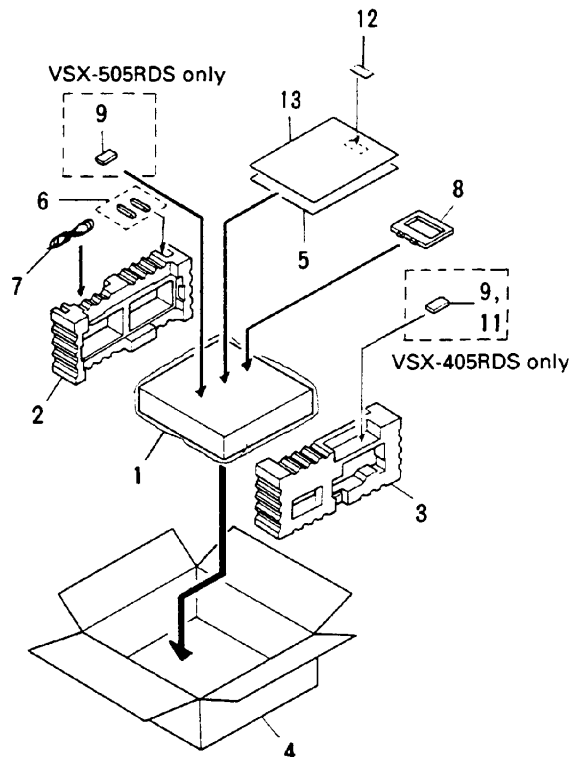

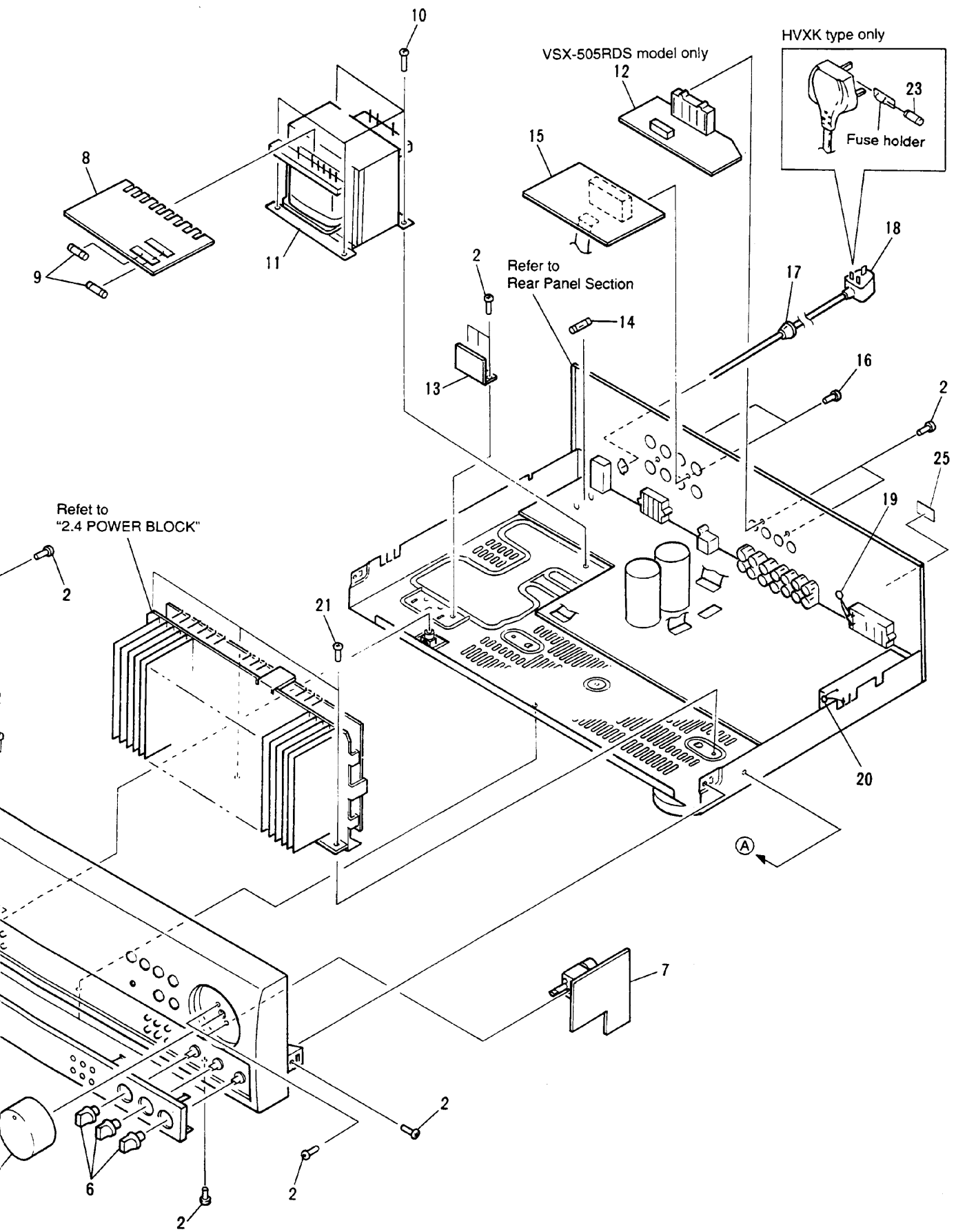

VSX-505RDS, VSX-405RDS

2.3 EXTERIOR

■ **CONTRAST OF VSX-505RDS/HVXK, HYXK/EW, HYXK/GR, VSX-405RDS/HVXK, HYXK/EW AND HYXK/GR**
 VSX-505RDS/HVXK, HYXK/EW, HYXK/GR, VSX-405RDS/HVXK, HYXK/EW and HYXK/GR have the same construction except for the following:

Mark	No.	Symbol & Description	Part No.						Remarks
			VSX-505RDS			VSX-405RDS			
			HVXK	HYXK/EW	HYXK/GR	HVXK	HYXK/EW	HYXK/GR	
NSP △	1	Bonnet case	ANE7103	ANE7102	ANE7102	ANE7103	ANE7102	ANE7102	
	12	VIDEO ASSY	AWZ8066	AWZ8066	AWZ8066	Not Used	Not Used	Not Used	
	18	AC power cord	ADG1148	ADG1138	ADG1138	ADG1148	ADG1138	ADG1138	
	22	Top cover	AME1086	Not Used	Not Used	AME1086	Not Used	Not Used	
	23	Fuse (T5A/250V)	AEK1046	Not Used	Not Used	AEK1046	Not Used	Not Used	

■ PARTS LIST FOR VSX-505RDS/HVXK

Mark	No.	Description	Part No.
	1	Bonnet case	ANE7103
	2	Screw	BBZ30P080FZK
	3	Badge	PAM1608
	4	FL panel	AAK7238
	5	Round knob L	AAB7082
	6	Round knob S	AAB7083
NSP	7	VOL. ASSY	AWZ8079
△	8	TRANS ASSY	AWZ8073
	9	Fuse (FU3, FU4, T1.25AL125V)	AEK1055
	10	Screw	ABA7019
△	11	Power transformer (T1, AC230V)	ATS7118
NSP	12	VIDEO ASSY	AWZ8066
NSP	13	REG. ASSY	AWZ8067
△	14	Fuse (FU1, T2.5AL250V)	AEK1058
NSP	15	FRONT SP. ASSY	AWZ8082
	16	Screw	ABA1007
	17	Strain relief	CM-22B
△	18	AC power cord	ADG1148
	19	Capacitor (C120)	CKDYB222K50
	20	Capacitor (C122)	CGDYX103M16
	21	Screw	ABA7019
△	22	Top cover	AME1086
	23	Fuse (T5A/250V, for AC power cord)	AEK1046
	24	Screw	BCZ30P080FZK
	25	Serial sheet	AAX1523
	26	Bonnet holder	ANG7105
	27	Screw	BPZ26P080FMC

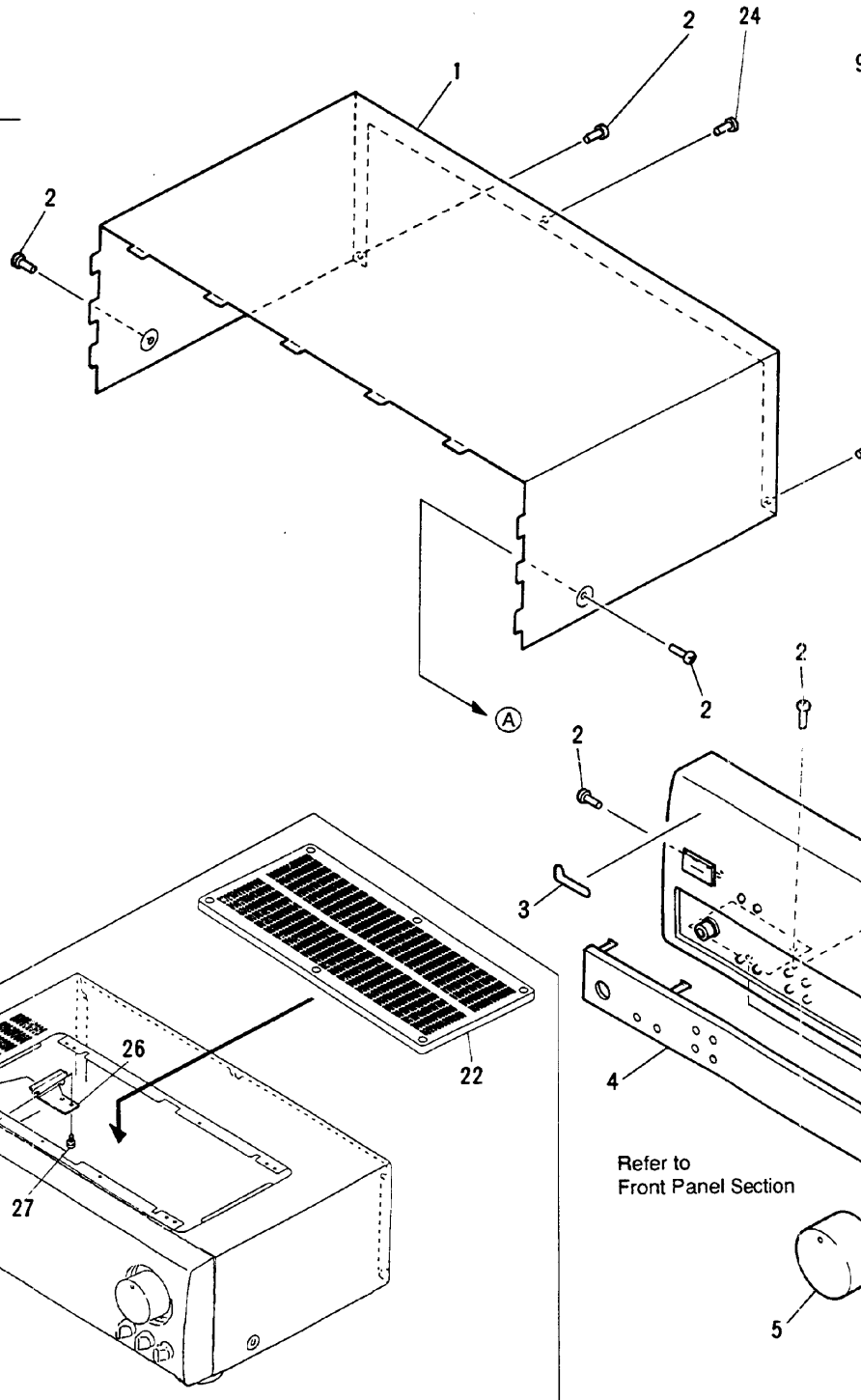

Refer to
Front Panel Section

HVXK type only

VSX-505RDS, VSX-405RDS

2.3 EXTERIOR

■ CONTRAST OF VSX-505RDS/HVXK, HYXK/EW, HYXK/GR, VSX-405RDS/HVXK, HYXK/EW AND HYXK/GR

VSX-505RDS/HVXK, HYXK/EW, HYXK/GR, VSX-405RDS/HVXK, HYXK/EW and HYXK/GR have the same construction except for the following:

Mark	No.	Symbol & Description	Part No.						Remarks
			VSX-505RDS			VSX-405RDS			
			HVXK	HYXK/EW	HYXK/GR	HVXK	HYXK/EW	HYXK/GR	
NSP △	1	Bonnet case	ANE7103	ANE7102	ANE7102	ANE7103	ANE7102	ANE7102	
	12	VIDEO ASSY	AWZ8066	AWZ8066	AWZ8066	Not Used	Not Used	Not Used	
	18	AC power cord	ADG1148	ADG1138	ADG1138	ADG1148	ADG1138	ADG1138	
	22	Top cover	AME1086	Not Used	Not Used	AME1086	Not Used	Not Used	
	23	Fuse (T5A/250V)	AEK1046	Not Used	Not Used	AEK1046	Not Used	Not Used	

■ PARTS LIST FOR VSX-505RDS/HVXK

Mark	No.	Description	Part No.
	1	Bonnet case	ANE7103
	2	Screw	BBZ30P080FZK
	3	Badge	PAM1608
	4	FL panel	AAK7238
	5	Round knob L	AAB7082
	6	Round knob S	AAB7083
	7	VOL. ASSY	AWZ8079
NSP	8	TRANS ASSY	AWZ8073
△	9	Fuse (FU3, FU4, T1.25AL125V)	AEK1055
	10	Screw	ABA7019
△	11	Power transformer (T1, AC230V)	ATS7118
NSP	12	VIDEO ASSY	AWZ8066
NSP	13	REG. ASSY	AWZ8067
△	14	Fuse (FU1, T2.5AL250V)	AEK1058
NSP	15	FRONT SP. ASSY	AWZ8082
	16	Screw	ABA1007
	17	Strain relief	CM-22B
△	18	AC power cord	ADG1148
	19	Capacitor (C120)	CKDYB222K50
	20	Capacitor (C122)	CGDYX103M16
	21	Screw	ABA7019
	22	Top cover	AME1086
△	23	Fuse (T5A/250V, for AC power cord)	AEK1046
	24	Screw	BCZ30P080FZK
	25	Serial sheet	AAX1523
	26	Bonnet holder	ANG7105
	27	Screw	BPZ26P080FMC

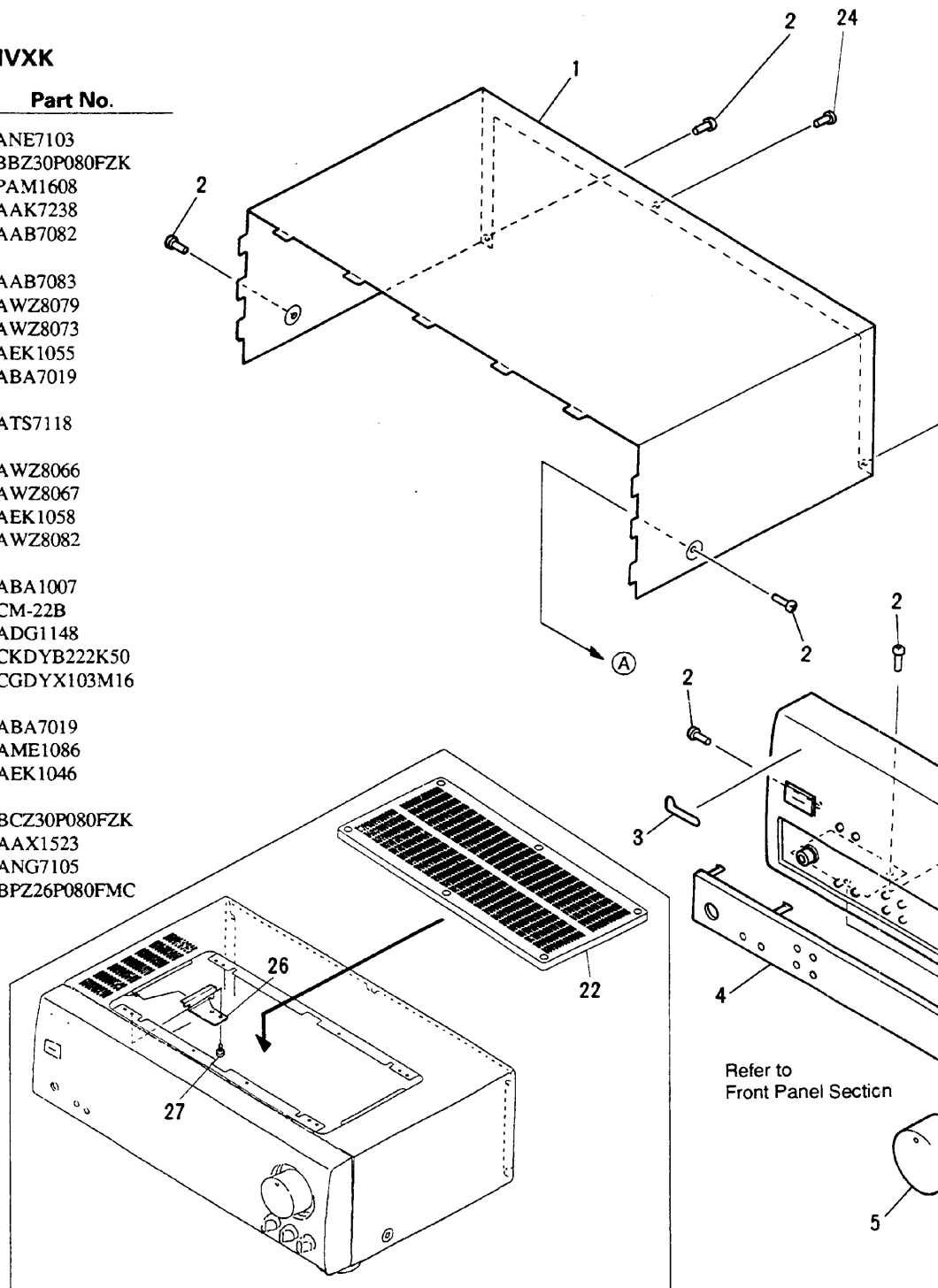

HVXK type only

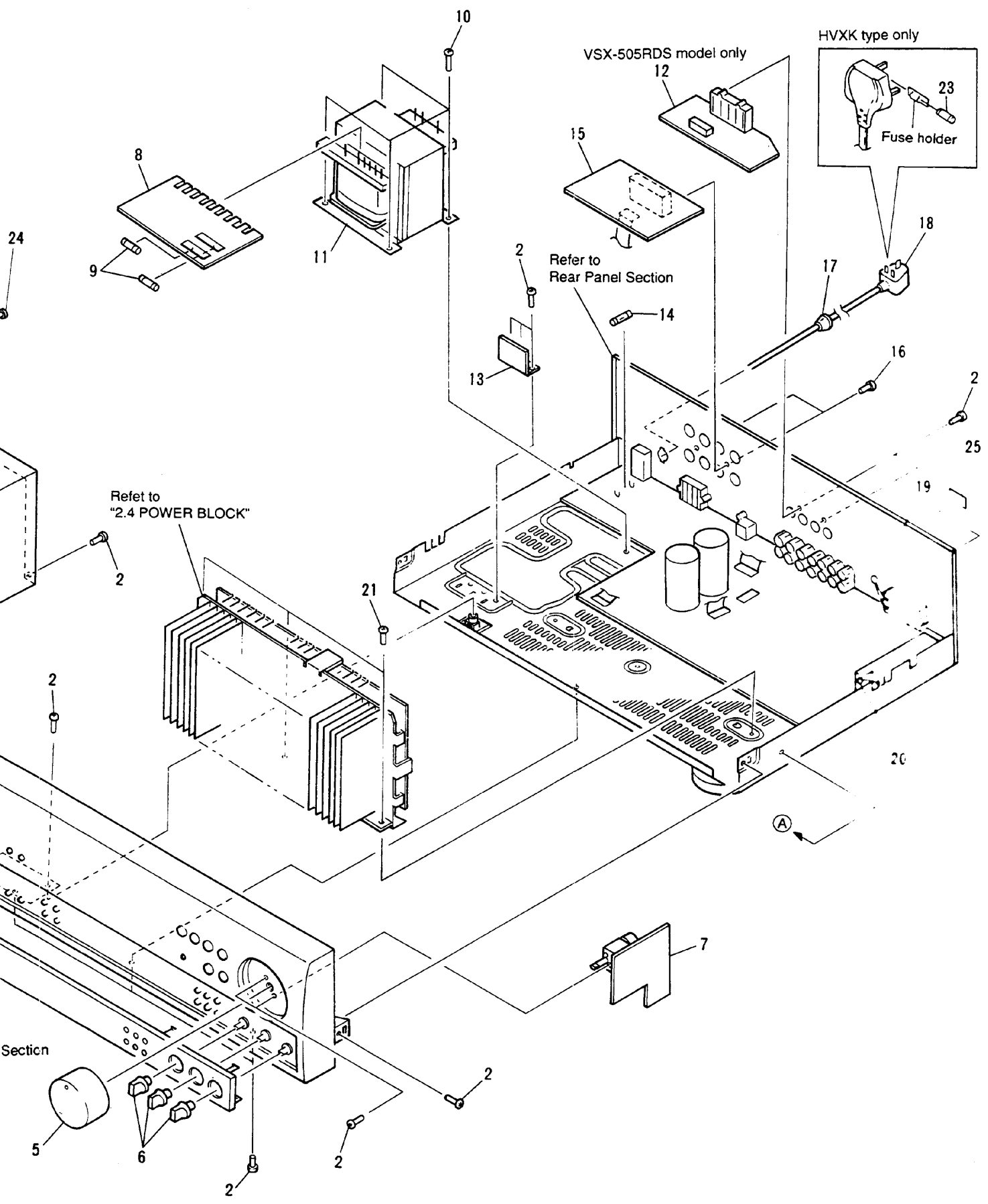

2.4 POWER BLOCK

■ PARTS LIST POWER BLOCK

Mark	No.	Description	Part No.
NSP	1	Radiator	ANH7037
	2	Mica wafer	AEE7010(P)
△	3	Transistor (Q3)	2SA1940(P)
△	4	Transistor (Q4)	2SA1940(P)
△	5	Transistor (Q13)	2SA1940(P)
△	6	Transistor (Q14)	2SA1940(P)
△	7	Transistor (Q1)	2SC5197(P)
△	8	Transistor (Q2)	2SC5197(P)
△	9	Transistor (Q11)	2SC5197(P)
△	10	Transistor (Q12)	2SC5197(P)
	11	Screw	ABA1037
	12	AMP ASSY	AWZ8076
	13	BBZ30P080FZK	

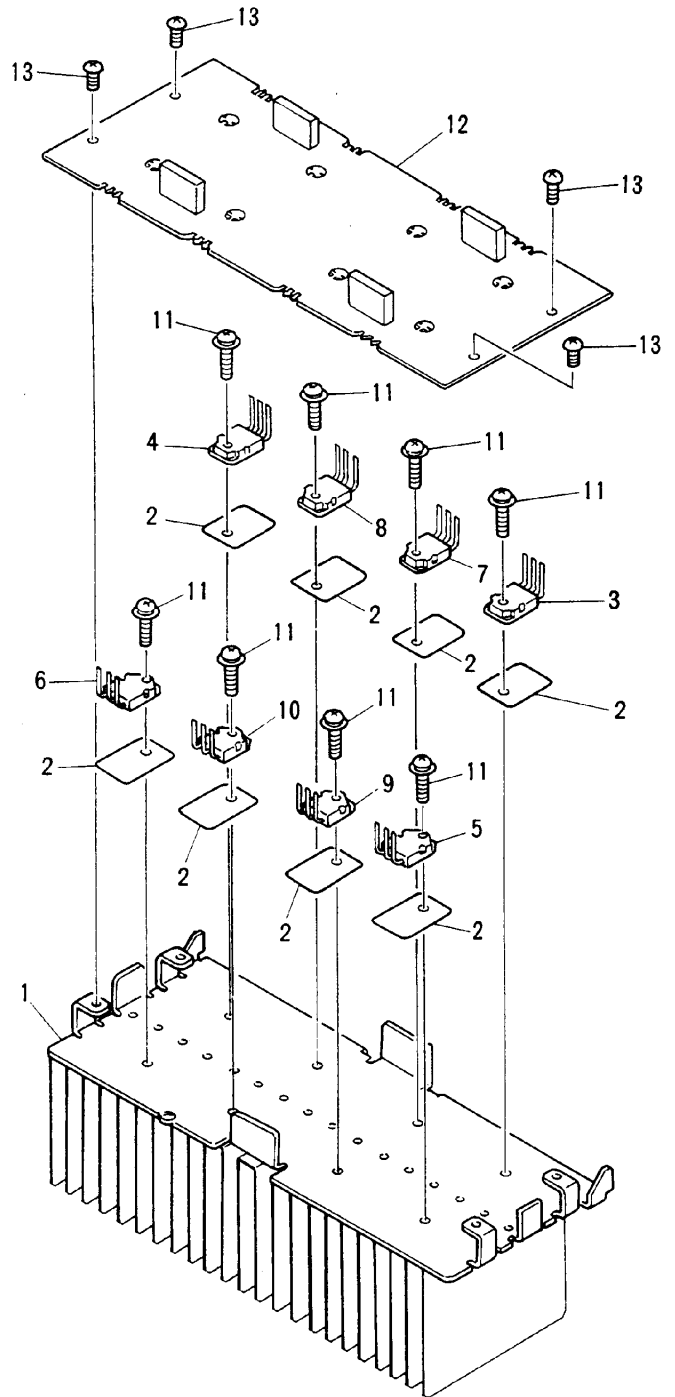

3. BLOCK DIAGRAM

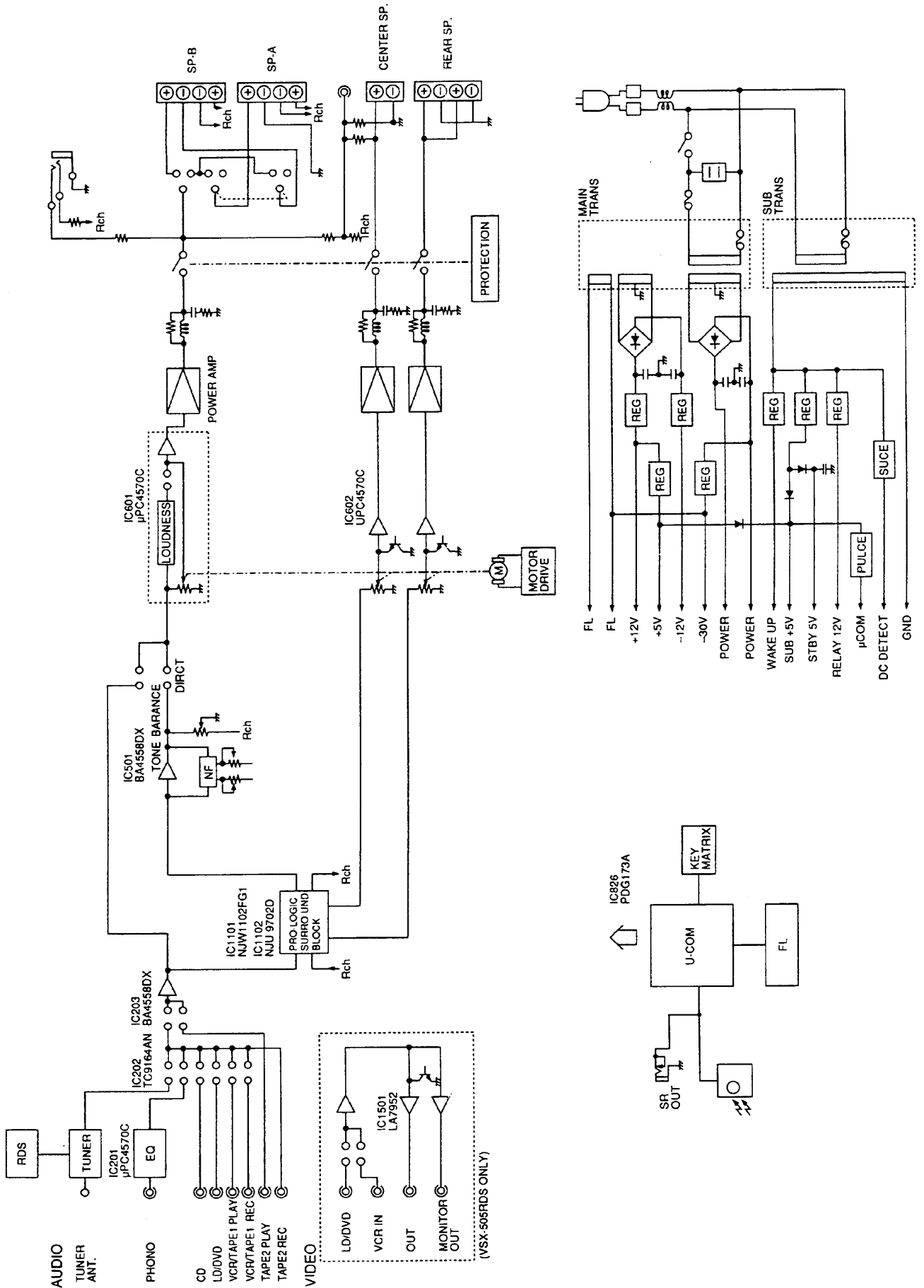

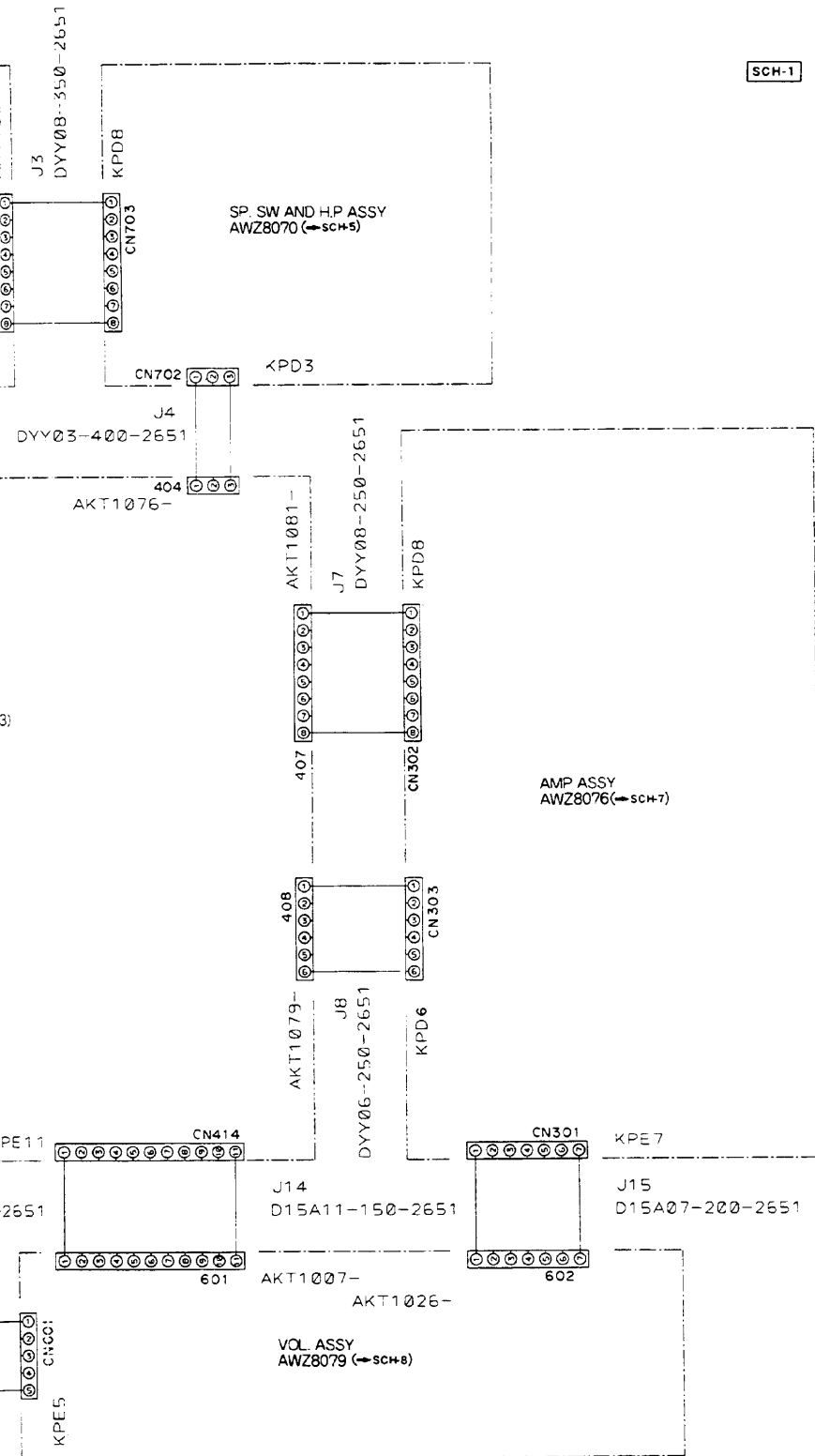

SCH-1

NOTE FOR SCHEMATIC DIAGRAMS

(Type 1A)

1. When ordering service parts, be sure to refer to "PARTS LIST of EXPLODED VIEWS" or "PCB PARTS LIST".

2. Since these are basic circuits, some parts of them or the values of some components may be changed for improvement.

3. RESISTORS:

Unit: k: k Ω , M: M Ω , or Ω unless otherwise noted.

Rated power: 1/4W, 1/6W, 1/8W, 1/10W unless otherwise noted.

Tolerance: (F): $\pm 1\%$, (G): $\pm 2\%$, (K): $\pm 10\%$, (M): $\pm 20\%$ or $\pm 5\%$ unless otherwise noted.

4. CAPACITORS:

Unit: p: pF or μ F unless otherwise noted.

Ratings: capacitor (μ F)/ voltage (V) unless otherwise noted.

Rated voltage: 50V except for electrolytic capacitors.

5. COILS:

Unit: m: mH or μ H unless otherwise noted.

6. VOLTAGE AND CURRENT:

: Signal voltage at rated output.

or - V :

DC voltage (V) at no input signal unless otherwise noted.

Value in () is DC voltage at rated power.

or - mA :

DC current at no input signal unless otherwise noted.

7. OTHERS:

or : Adjusting point.

: Measurement point.

The Δ mark found on some component parts indicates the importance of the safety factor of the parts. Therefore, when replacing, be sure to use parts of identical designation.

8. SCH-□ ON THE SCHEMATIC DIAGRAM:

SCH-□ indicates the drawing number of the schematic diagram. (SCH stands for schematic diagram.)

9. SWITCHES (Underline indicates switch position):

ST IND. ASSY

S876 : POWER STANDBY/ON

S877 : SFC MODE

S878 : DOLBY PRO LOGIC

FL AND UCOM ASSY

S825 : STATION +

S826 : STATION -

S827 : CLASS

S829 : EON MODE

S830 : TUNING +

S831 : TUNING -

S832 : FM/AM

S834 : CHARACTER/SEARCH

S835 : TAPE 2 MONITOR

S836 : VCR/TAPE 1

S837 : LOUDNESS

S839 : MEMORY

S840 : CD

S841 : LD/DVD

S842 : TUNER

S843 : PHONO

S844 : RF ATT

SP. SW AND HP. ASSY

S701 : SPEAKERS A OFF-ON

S702 : SPEAKERS B OFF-ON

OVERALL SCHEMATIC DIAGRAM

SCH-1

4. SCHEMATIC AND PCB CONNECTION DIAGRAMS

4.1 OVERALL SCHEMATIC DIAGRAM

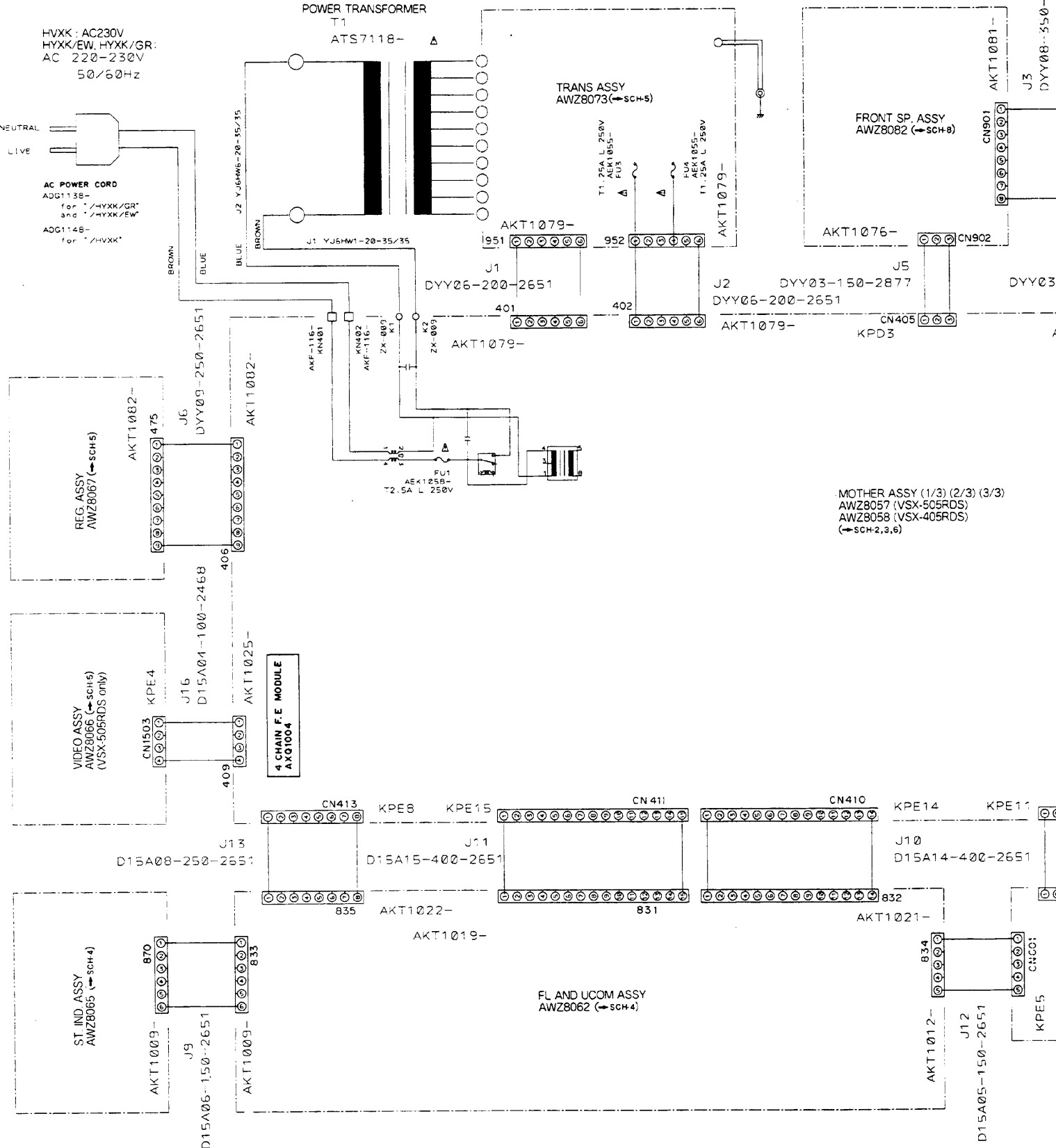

SCH-1

OVERALL SCHEMATIC DIAGRAM

4.2 MOTHER ASSY (1/3)

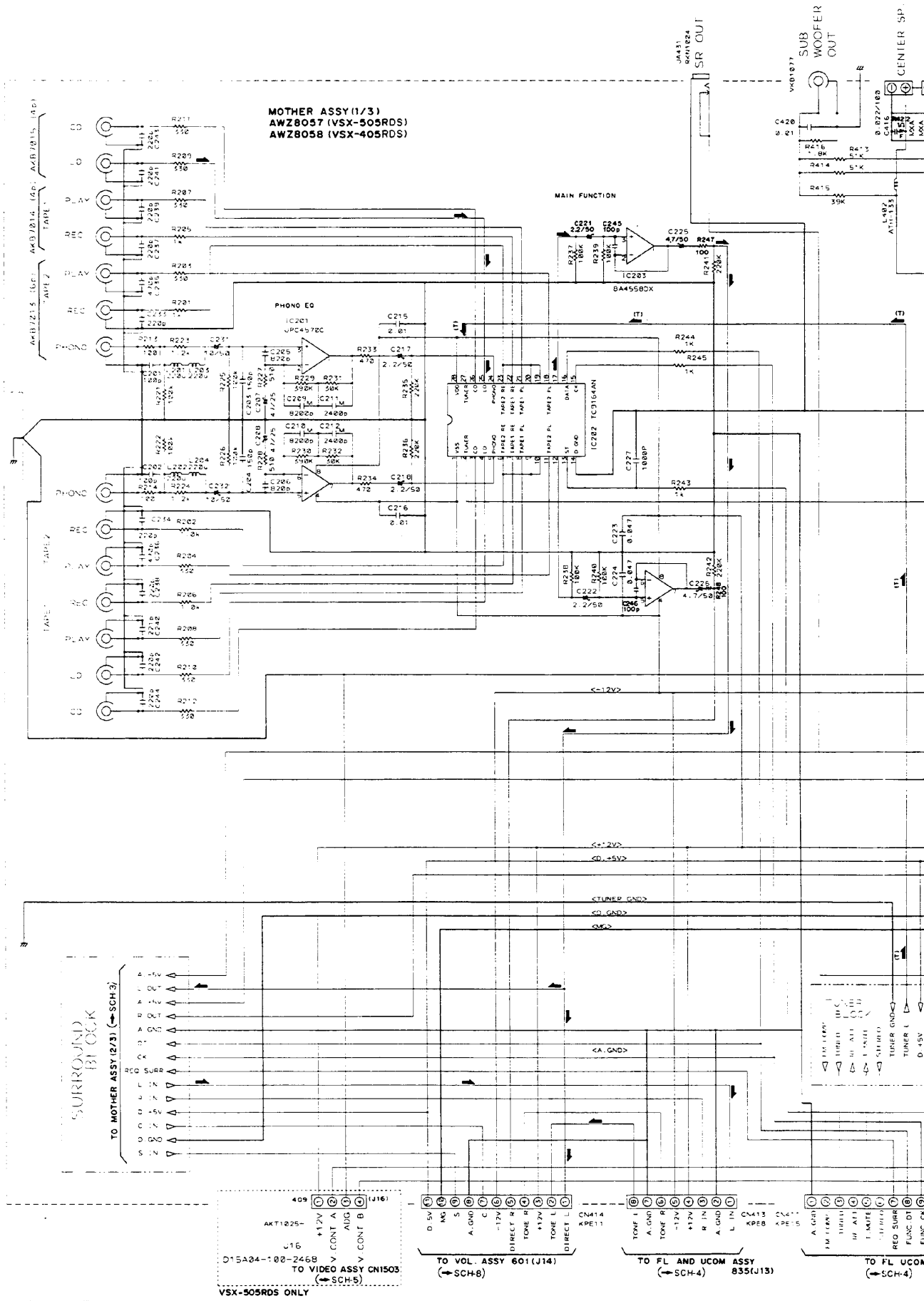

SCH-2

MOTHER ASSY (1/3)

VSX-505RDS, VSX-405RDS

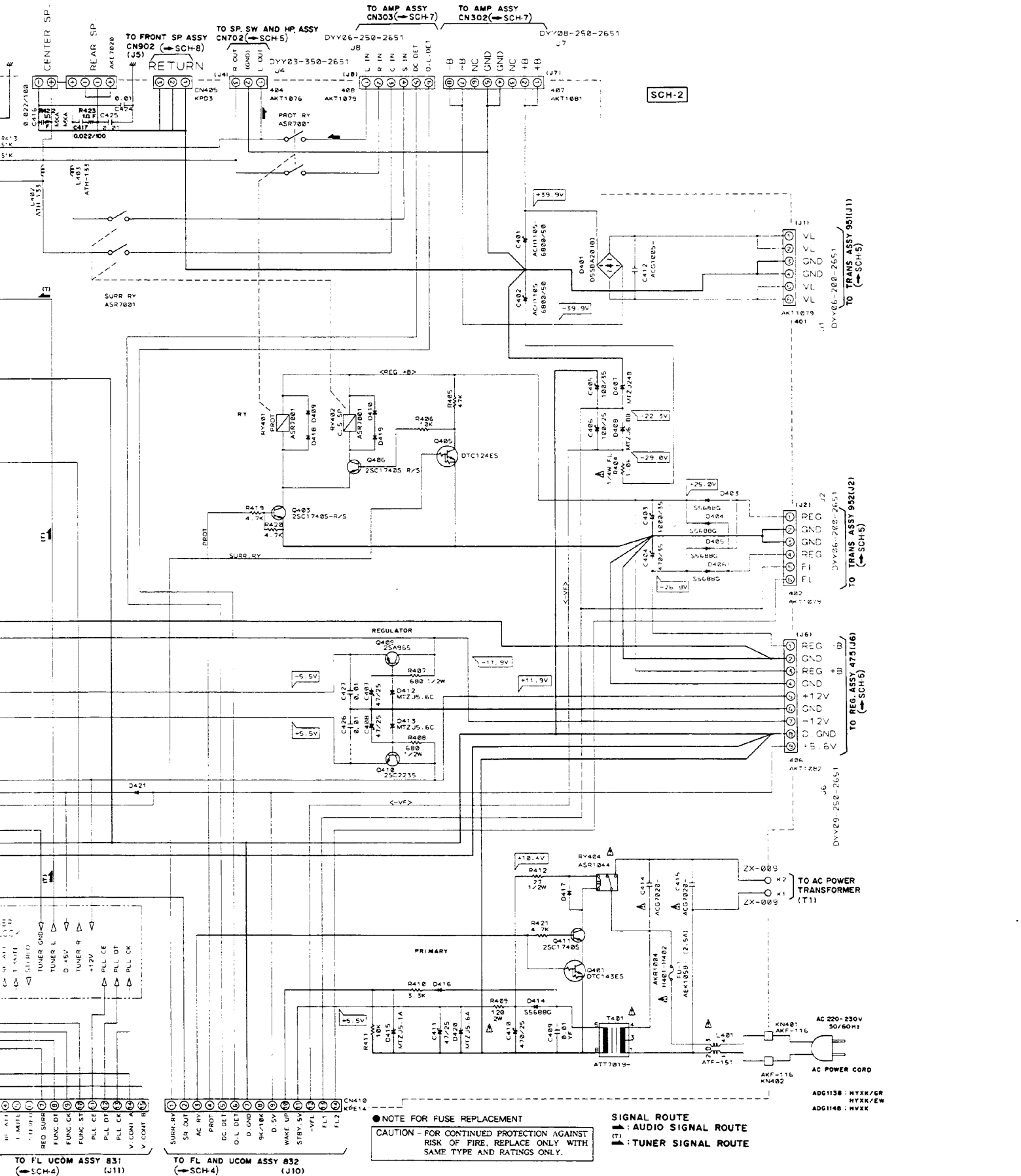

MOTHER ASSY (1/3)

SCH-2

VSX-505RDS, VSX-405RDS

4.3 MOTHER ASSY (2/3)

SURROUND BLOCK

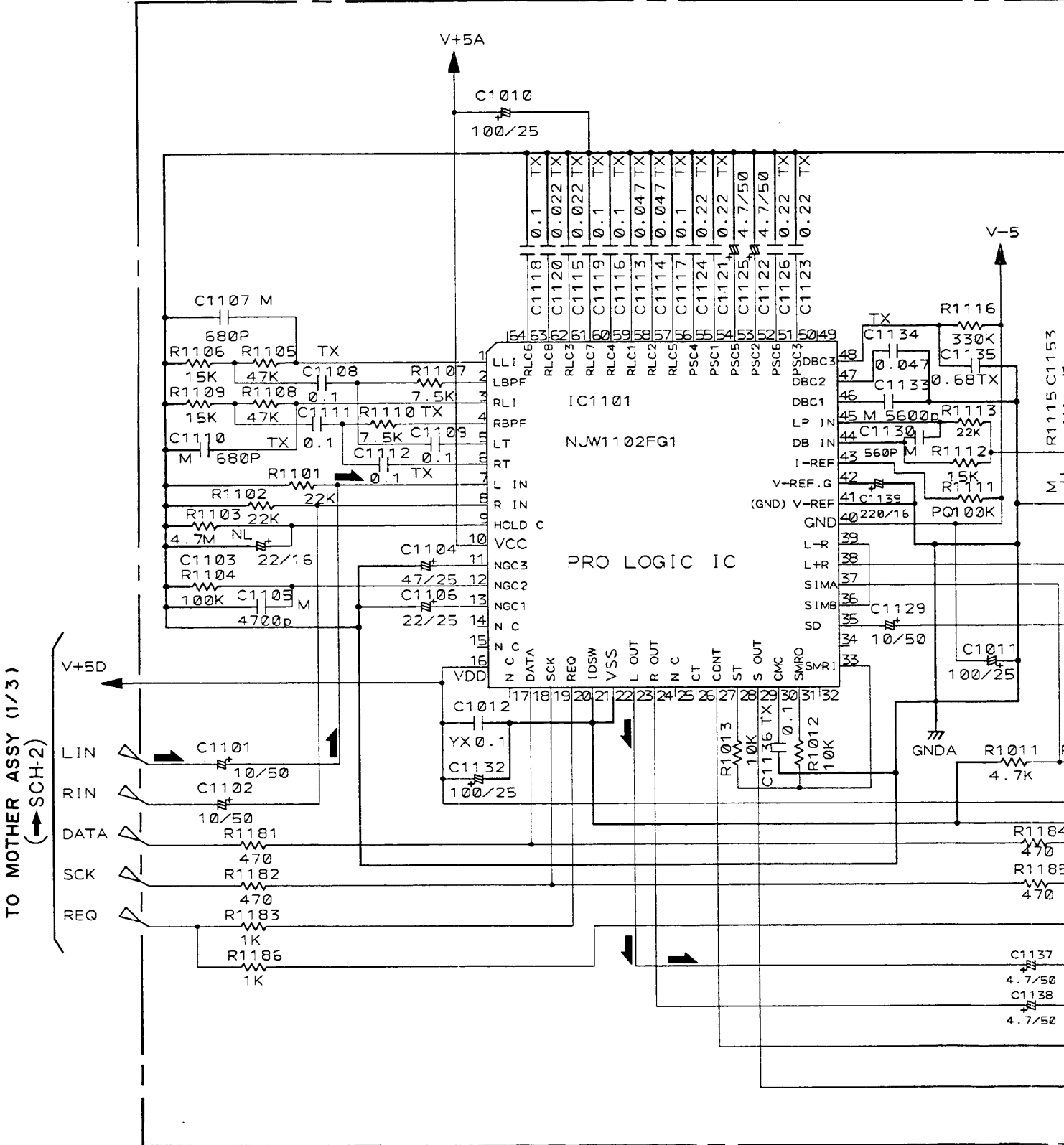

MOTHER ASSY (2/3)

SCH-3

MOTHER ASSY (2/3)
 AWZ8057 (VSX-505RDS)
 AWZ8058 (VSX-405RDS)

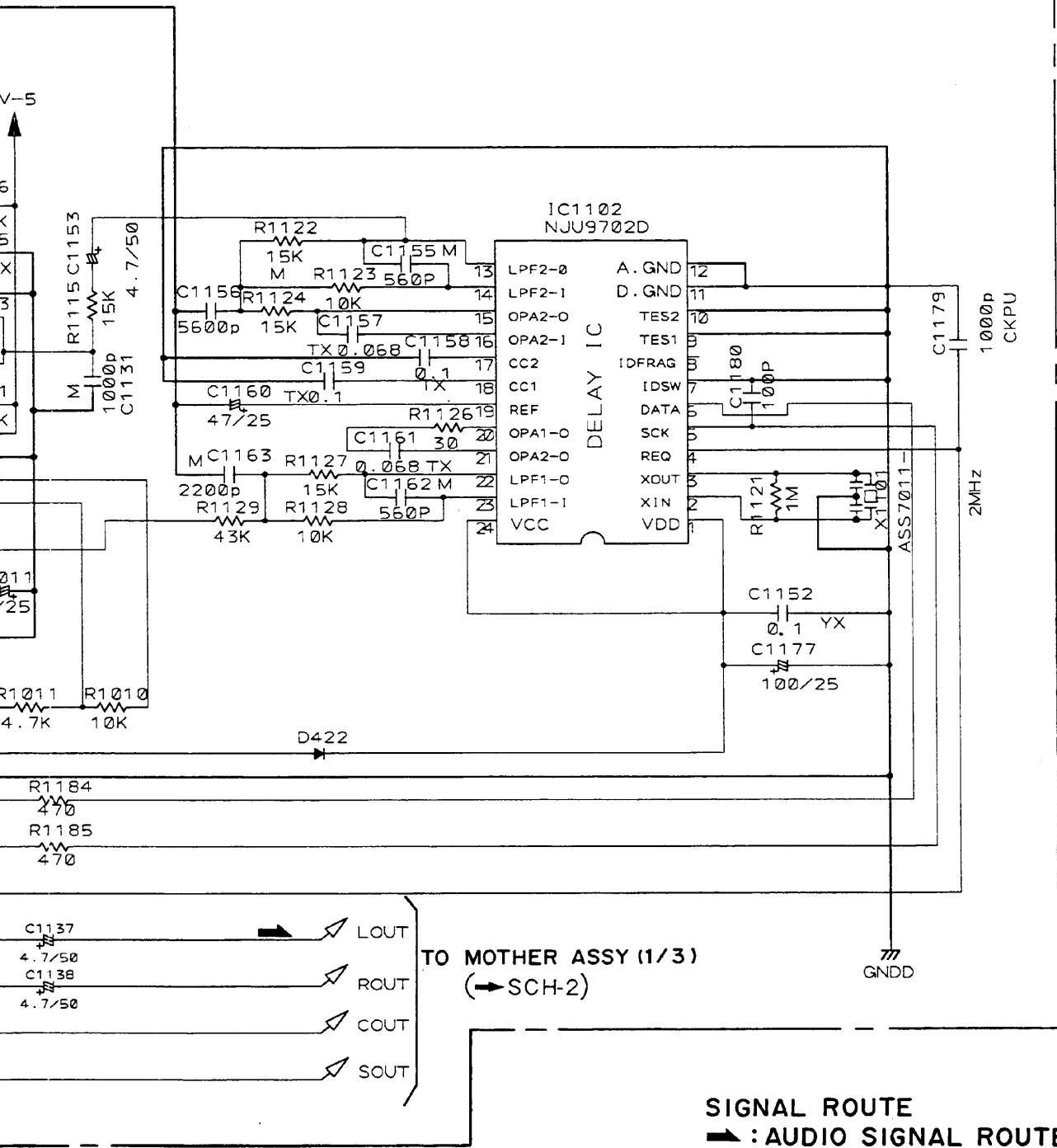

SIGNAL ROUTE
 ▲ : AUDIO SIGNAL ROUTE



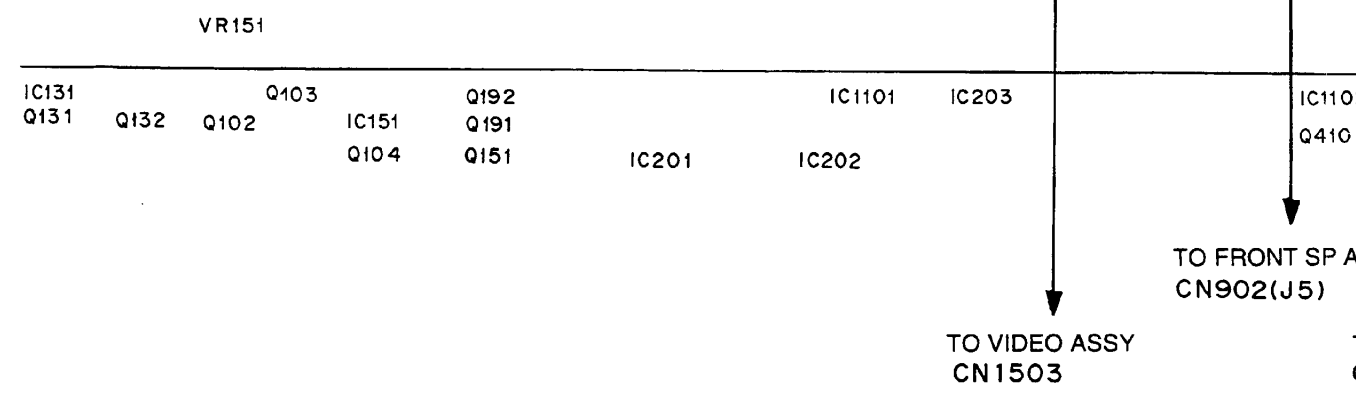
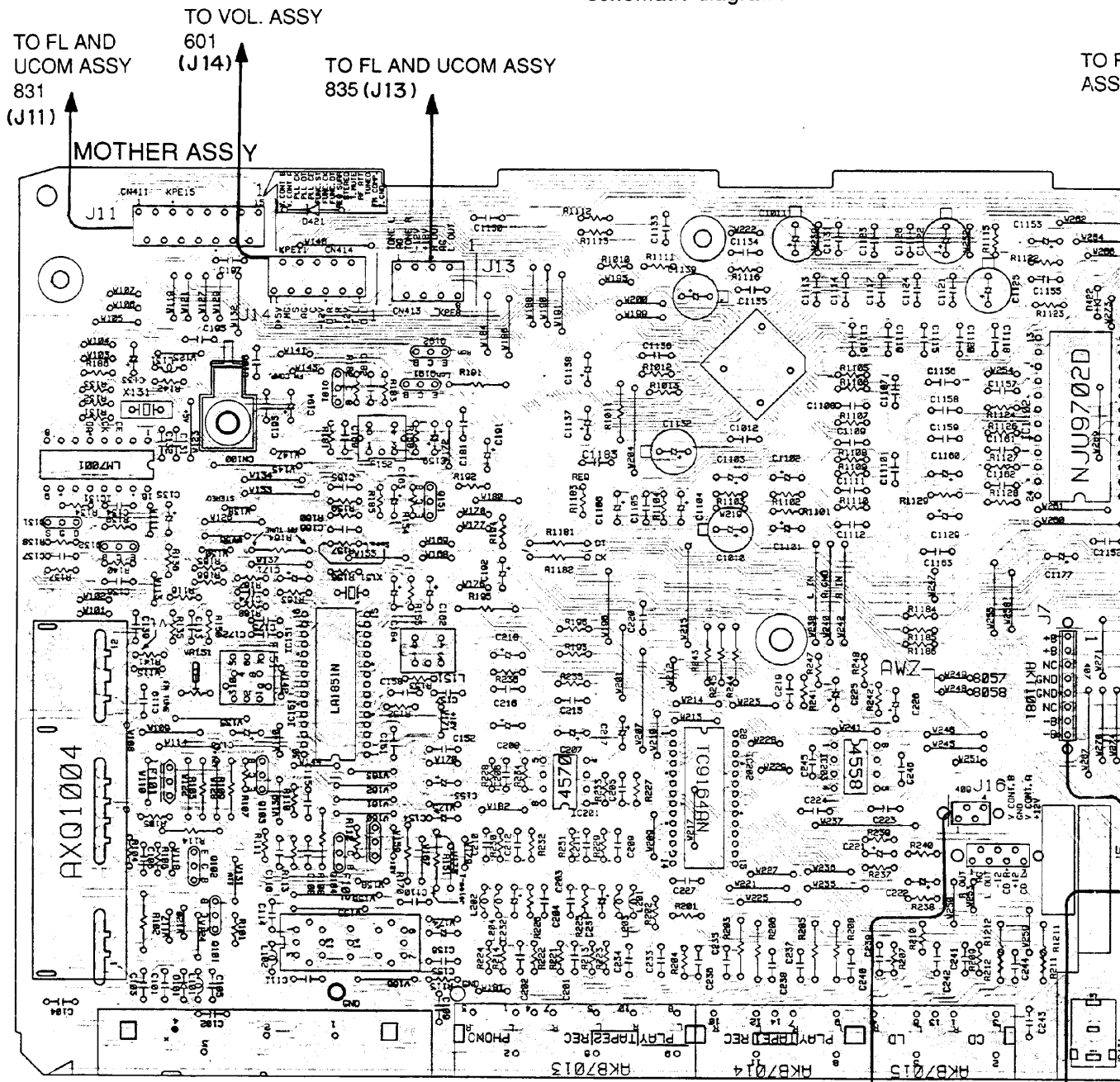



- The parts mounted on this PCB include all necessary parts for several destinations. For further information for respective destinations, be sure to check with the schematic diagram.

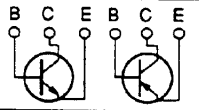

VSX-505RDS, VSX-405RDS

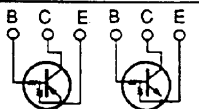
• This diagram is viewed from the mounted parts side.

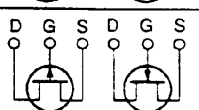
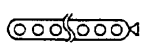
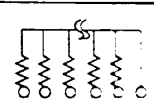
1. Part numbers in PCB diagrams match those in the schematic diagrams.
2. A comparison between the main parts of PCB and schematic diagrams is shown below.

Symbol in PCB Diagrams	Symbol in Schematic Diagrams	Part Name
		Transistor
		Transistor with resistor
		Field effect transistor
		Resistor array
		3-terminal regulator

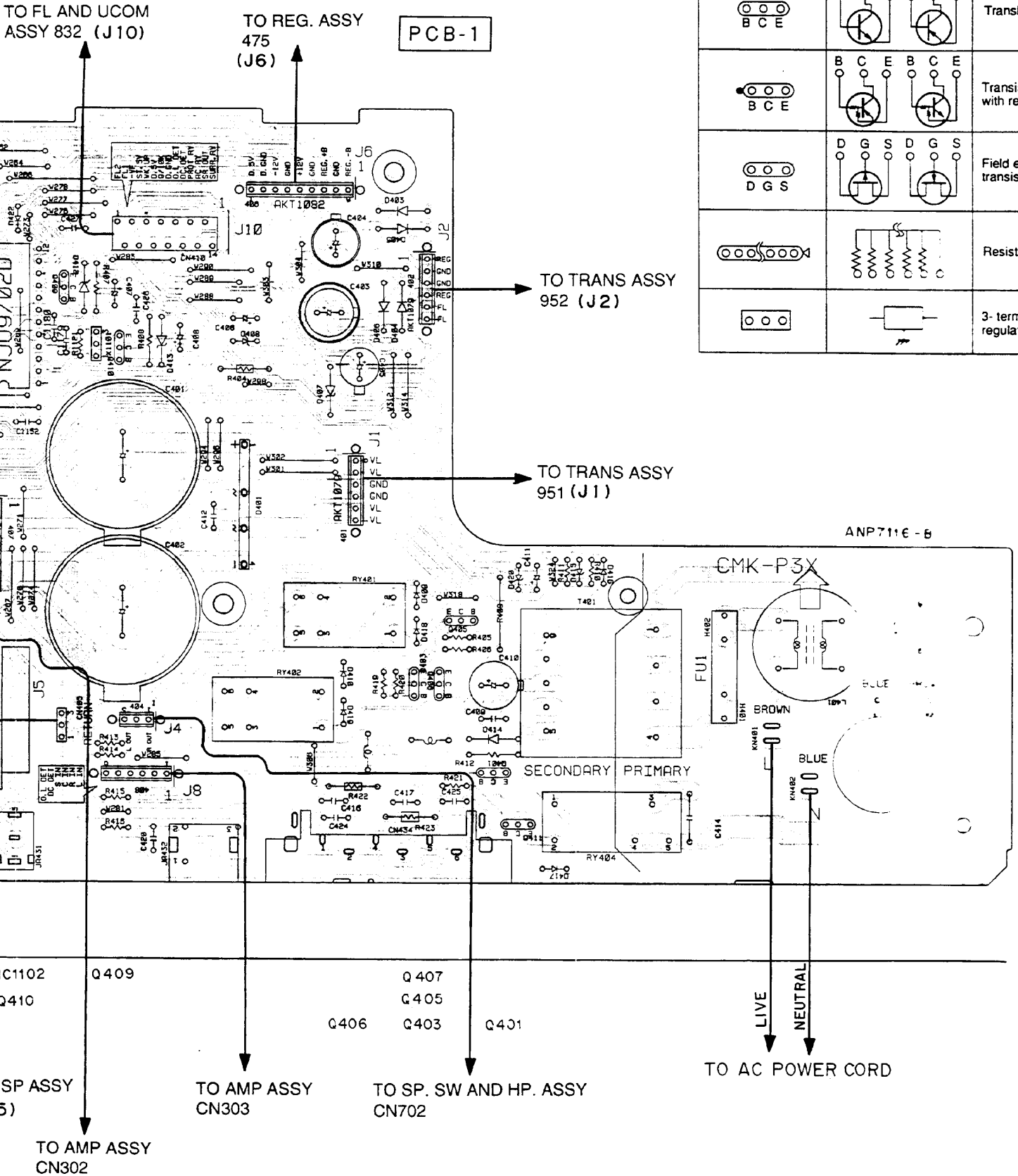

VSX-505RDS, VSX-405RDS

4.4 FL AND UCOM ASSY AND ST. IND. ASSY

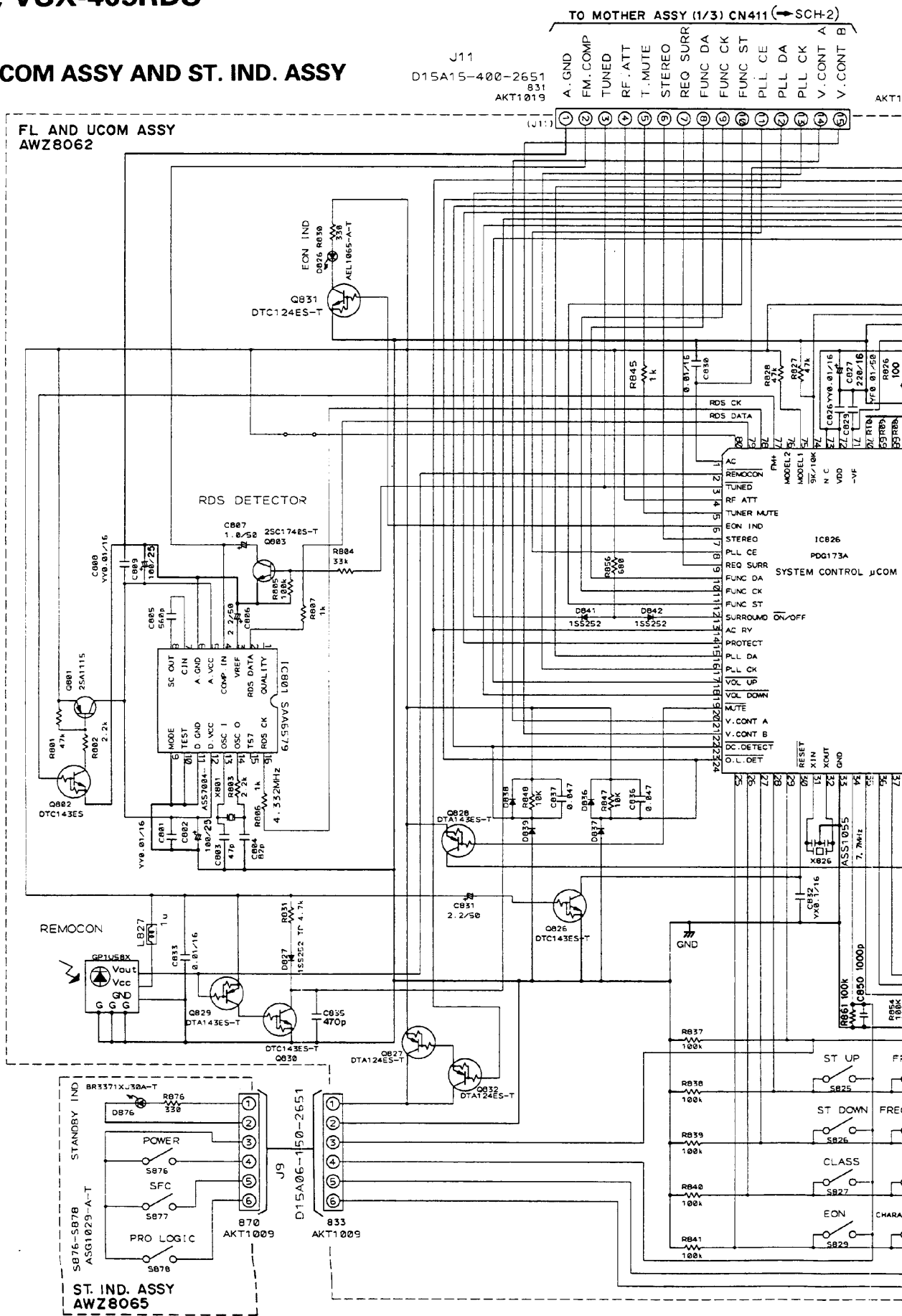

SCH-4

FL AND UCOM ASSY,
ST. IND. ASSY

TO MOTHER ASSY (1/3) CN410 (SCH-2)

SURR.RY
SR.OUT
AC.RY
PROT.RY
DC.DET
O.L.DET
DG
9K/10k
D +5V
W.UP
STBY5V
-VF
FL1
FL2

J10
D15A14-400-2651

AKT1021

SCH-4

SIGNAL ROUTE
AUDIO SIGNAL ROUTE

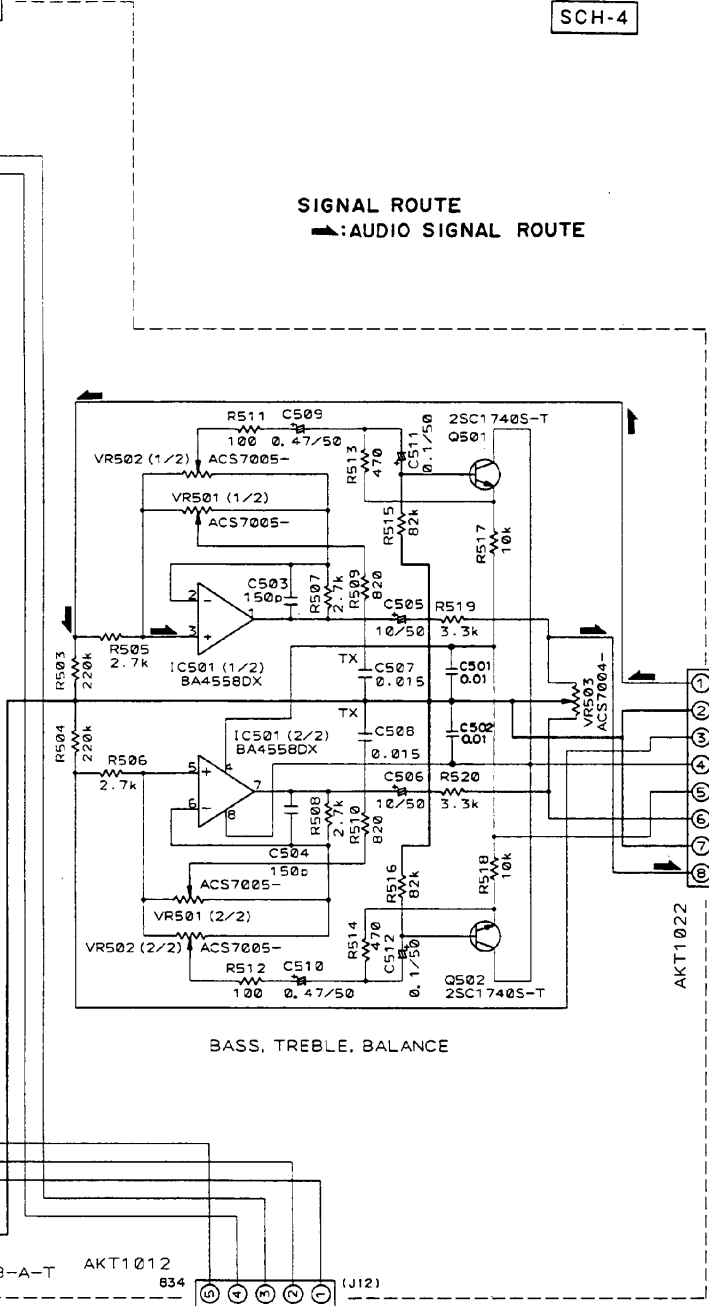
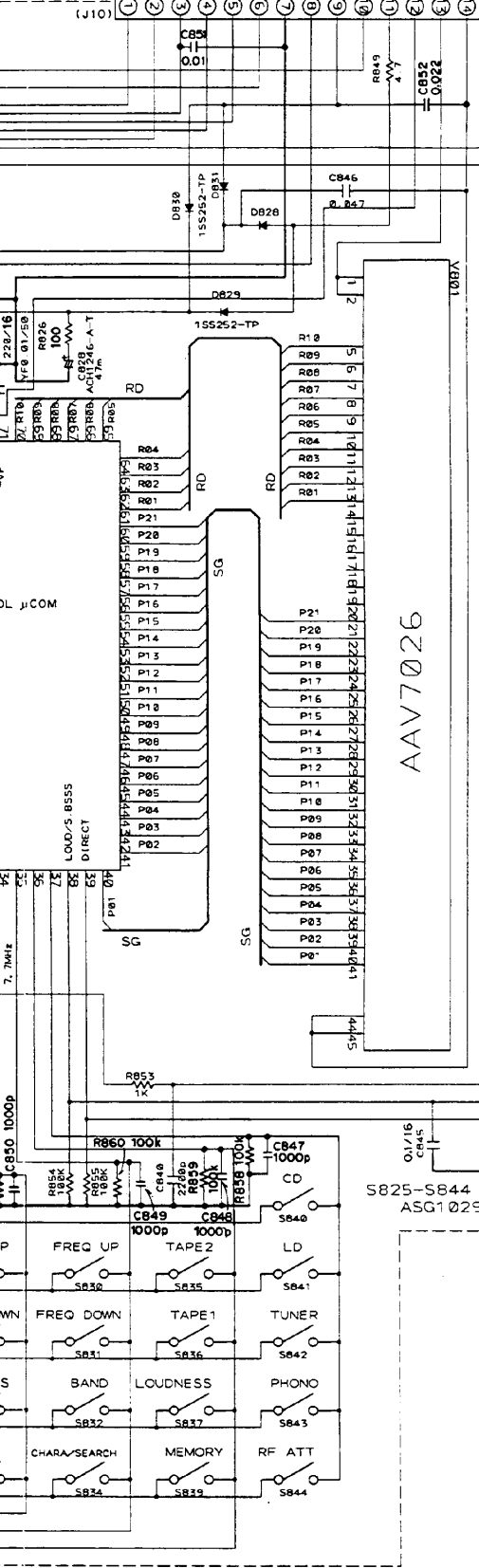

(J13)
L IN
GND
R IN
+12V
-12V
TONE R
GND
TONE L
AKT1022
D15A08-250-2651
J13

TO MOTHER ASSY (1/3)
CN413 (SCH-2)

J12
D15A05-150-2651
AUDIO MUTE
VOL UP
VOL DOWN
LOUDNESS
DIRECT
TO VOL ASSY
CN601 (SCH-8)
(J14)

FL AND UCOM ASSY,
ST. IND. ASSY

SCH-4

- This diagram is viewed from the mounted parts side.

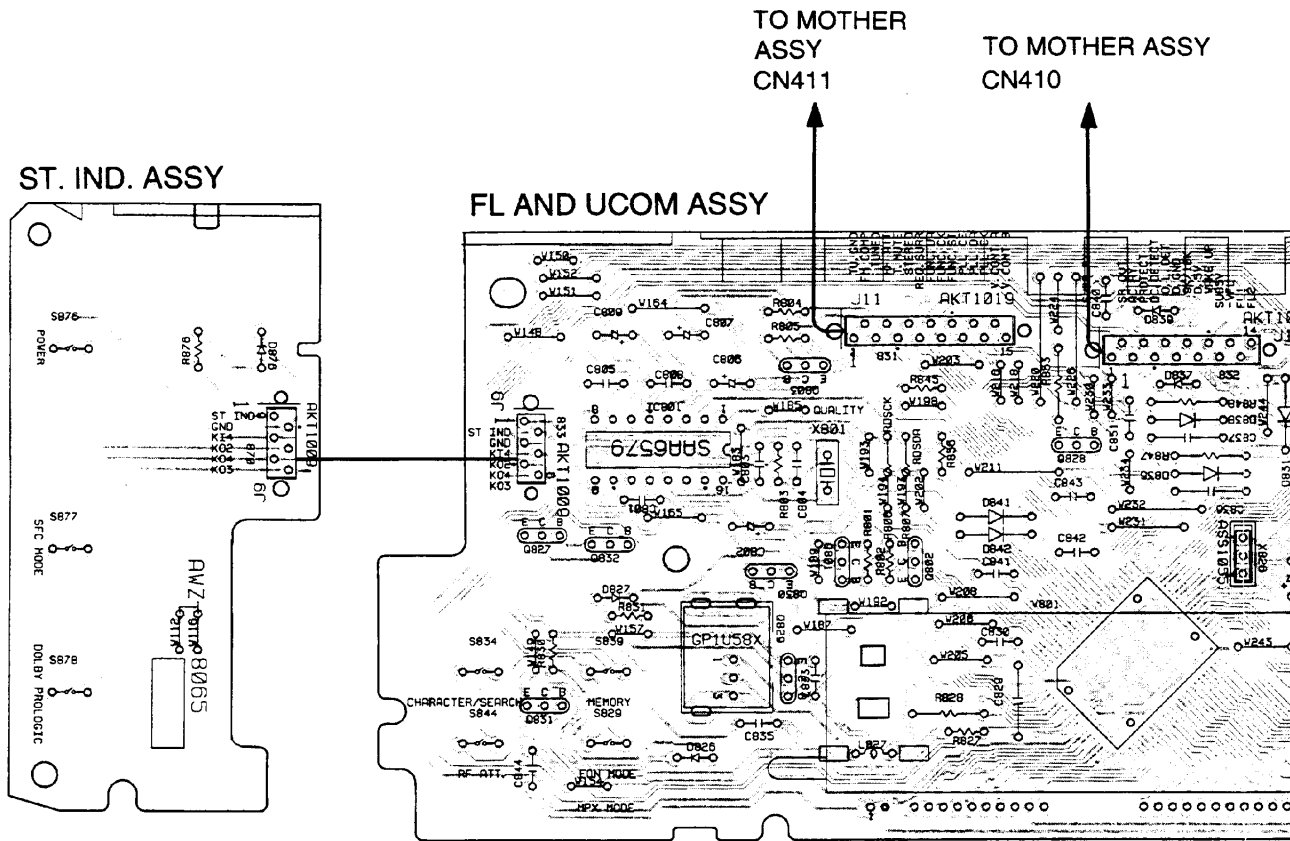

Q827

Q829

Q828

Q830

IC826

PCB-2

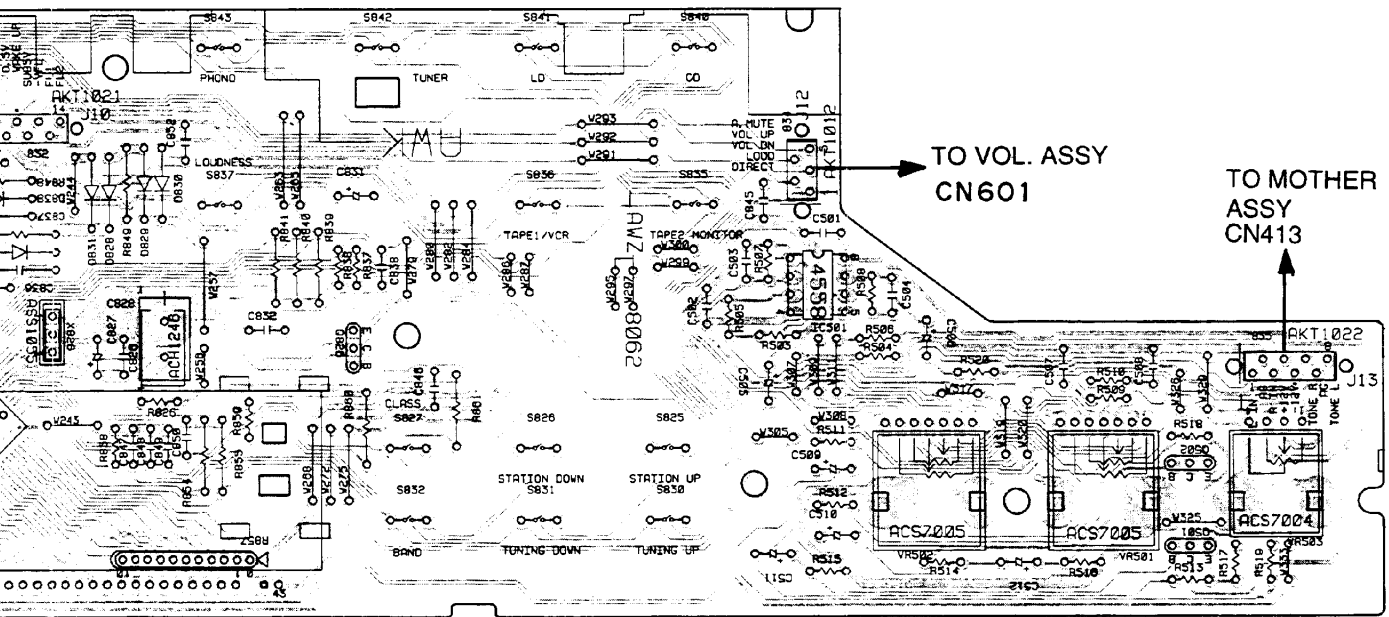

ANP7116 - B

VR502

VR501

VR503

Q326

IC501

- The parts mounted on this PCB include all necessary parts for several destinations. For further information for respective destinations, be sure to check with the schematic diagram.

SCH-5

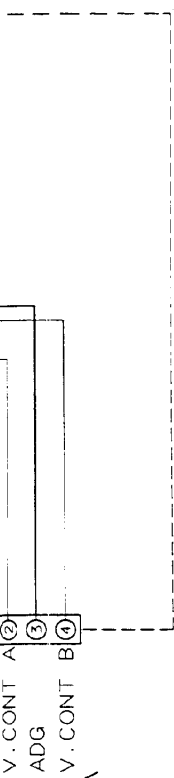
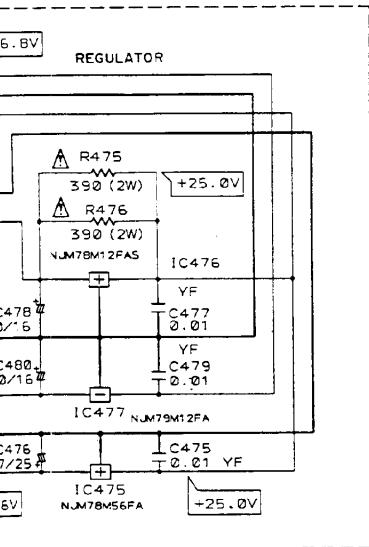

TO MOTHER
ASSY (1/3) 404 (J4)
(→ SCH-2)

TO MOTHER ASSY (1/3) 409 (J16)
(→ SCH-2)

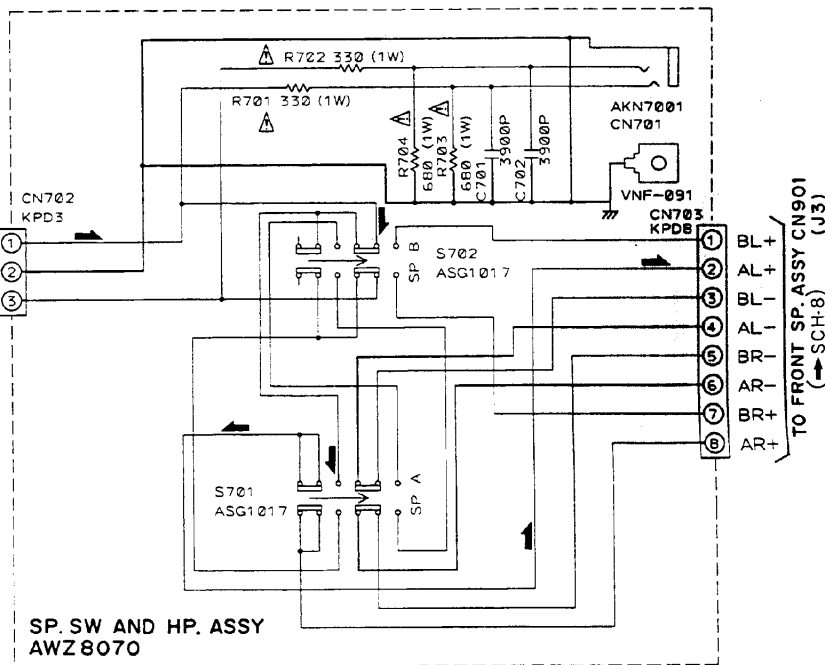

SP. SW AND HP. ASSY
AWZ8070

SIGNAL ROUTE
 —▶ : AUDIO SIGNAL ROUTE
 —▷ : VIDEO SIGNAL ROUTE

SP. SW AND HP. ASSY
 VIDEO ASSY,
 TRANS ASSY,
 REG. ASSY

SCH-5

VSX-505RDS, VSX-405RDS

4.5 SP. SW AND HP. ASSY, VIDEO ASSY, TRANS ASSY AND REG. ASSY

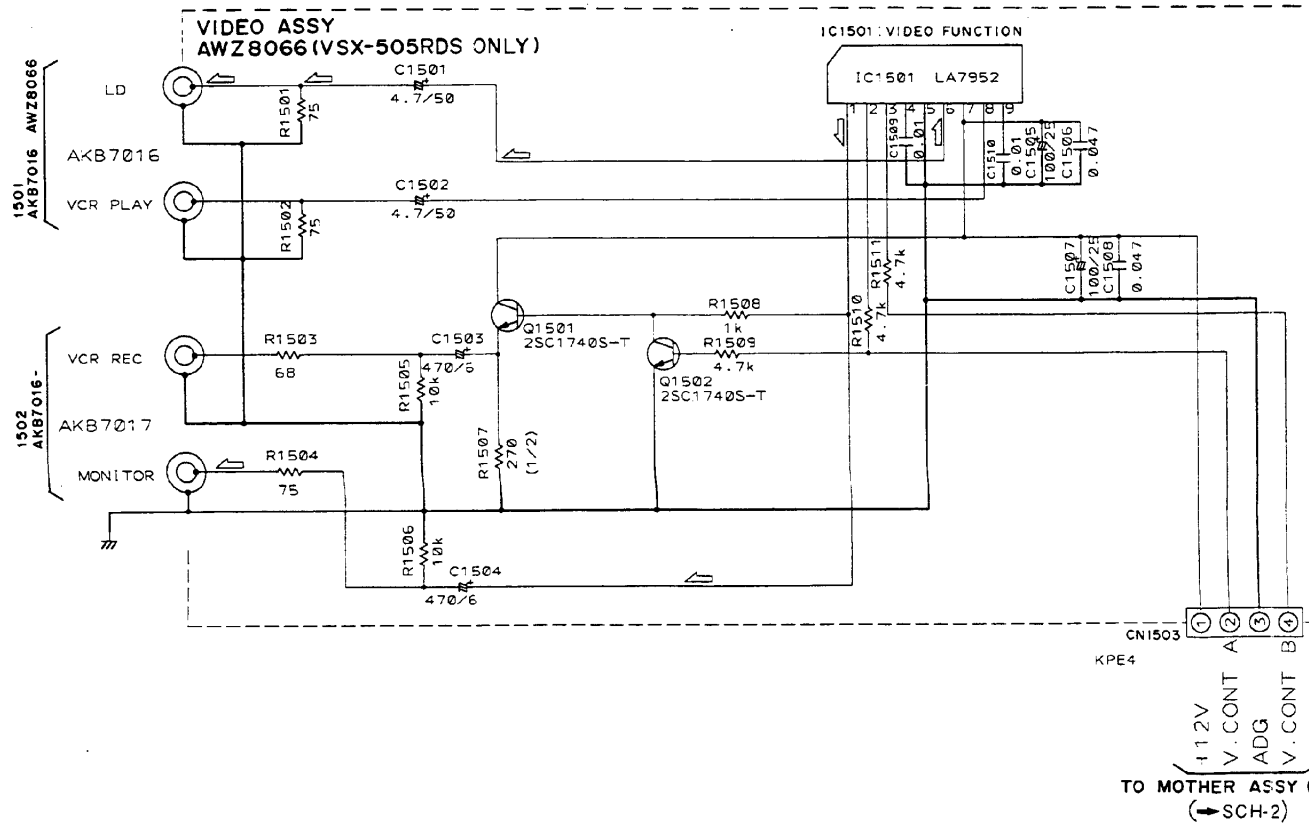
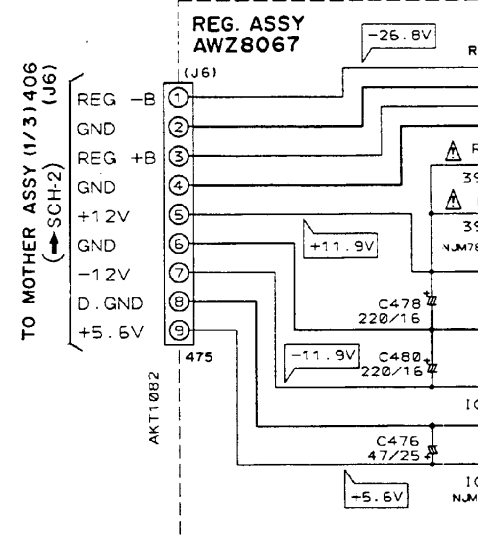
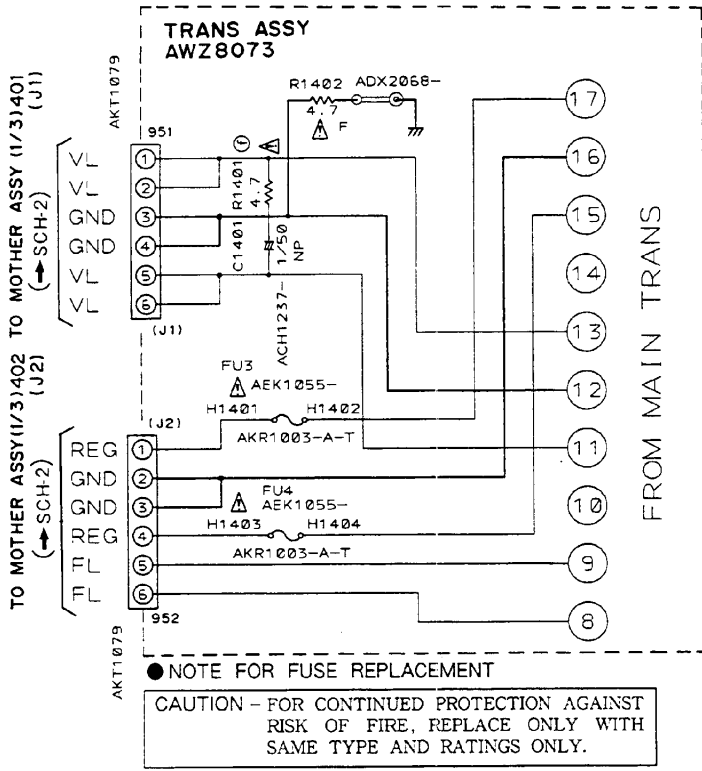

SCH-5

SP. SW AND HP. ASSY
VIDEO ASSY,
TRANS ASSY,
REG. ASSY

VSX-505RDS, VSX-405RDS

- The parts mounted on this PCB include all necessary parts for several destinations. For further information for respective destinations, be sure to check with the schematic diagram.

- This diagram is viewed from the mounted parts side.

PCB-3

SP. SW AND HP. ASSY

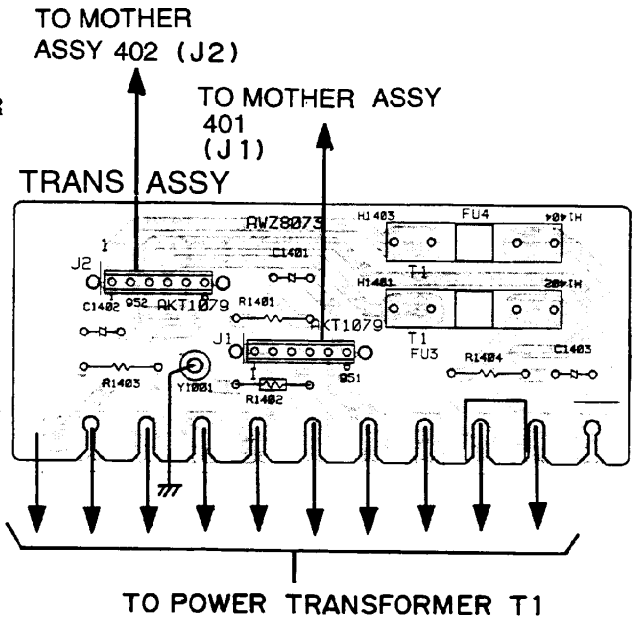
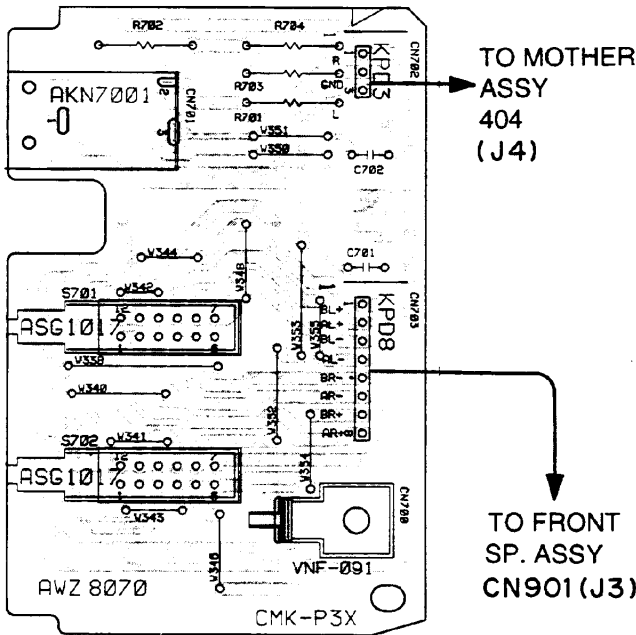

TO MOTHER ASSY 406 (J6)

REG. ASSY

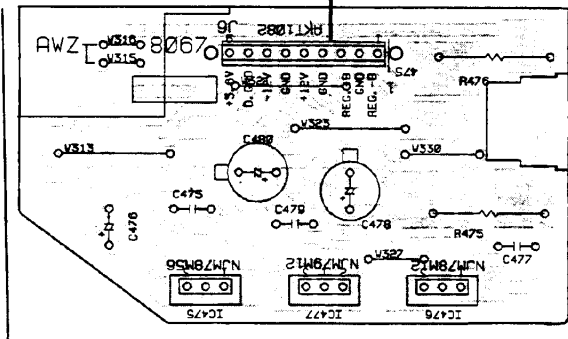

IC475
IC477
IC476

VIDEO ASSY (VSX-505RDS ONLY)

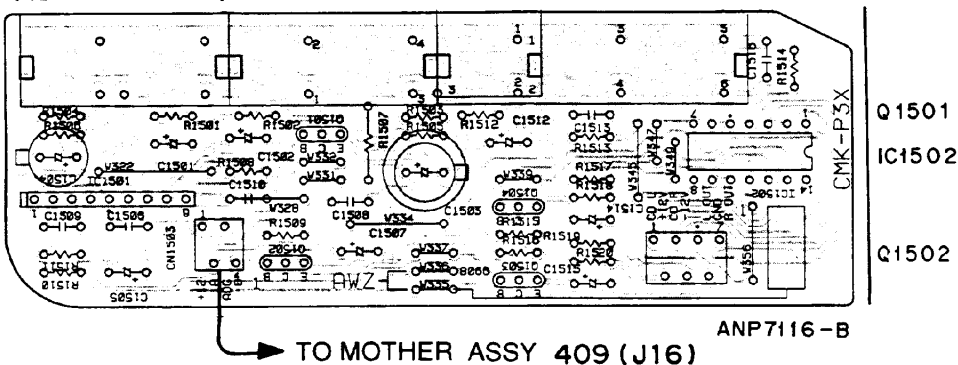

VSX-505RDS, VSX-405RDS

4.6 MOTHER ASSY (3/3)

TUNER BLOCK

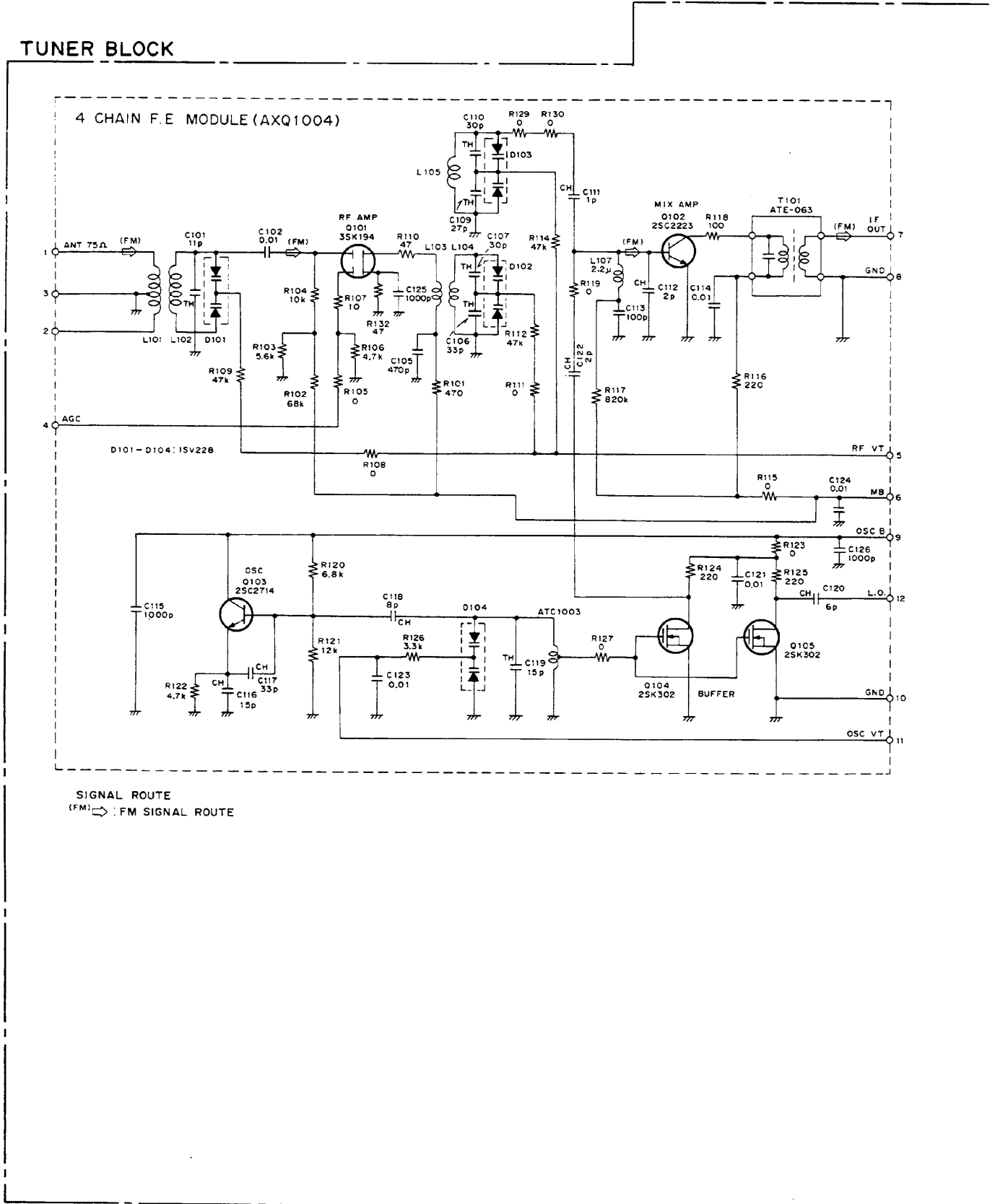

MOTHER ASSY (3/3)

SCH-6

MOTHER ASSY(3/3)
 AWZ8057 (VSX-505RDS)
 AWZ8058 (VSX-405RDS)

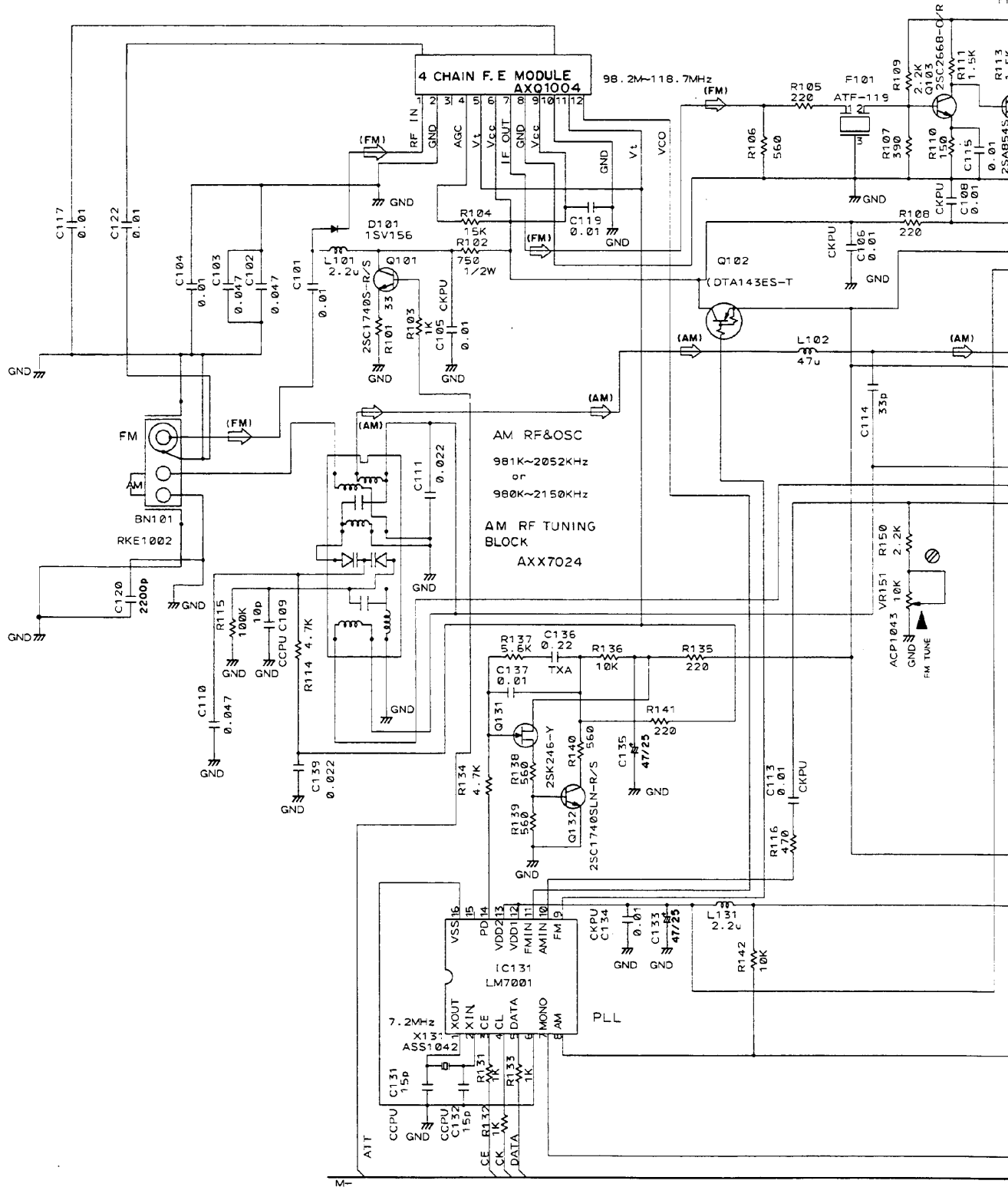

SCH-6

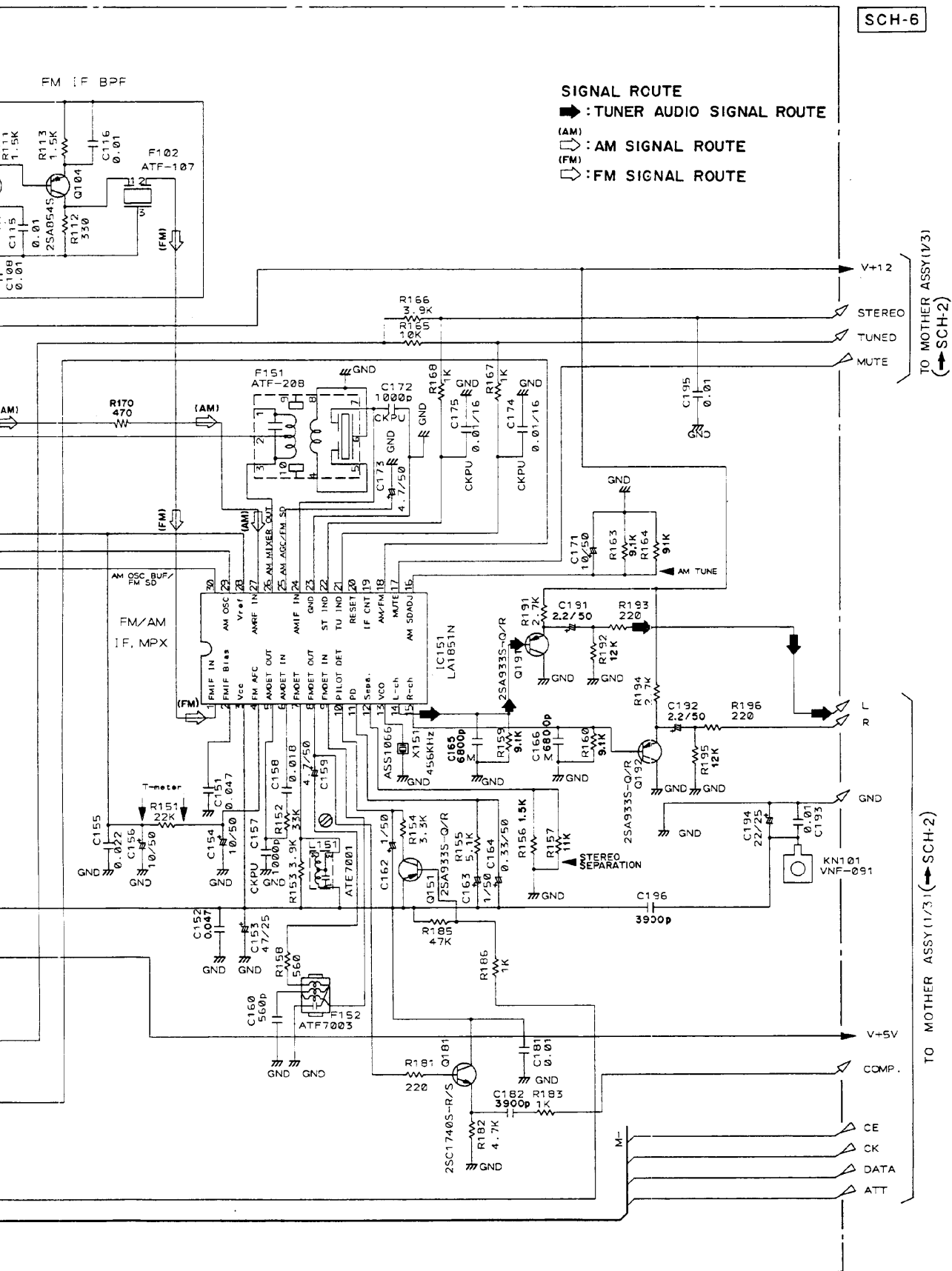

SCH-6

AMP ASSY
AWZ8076

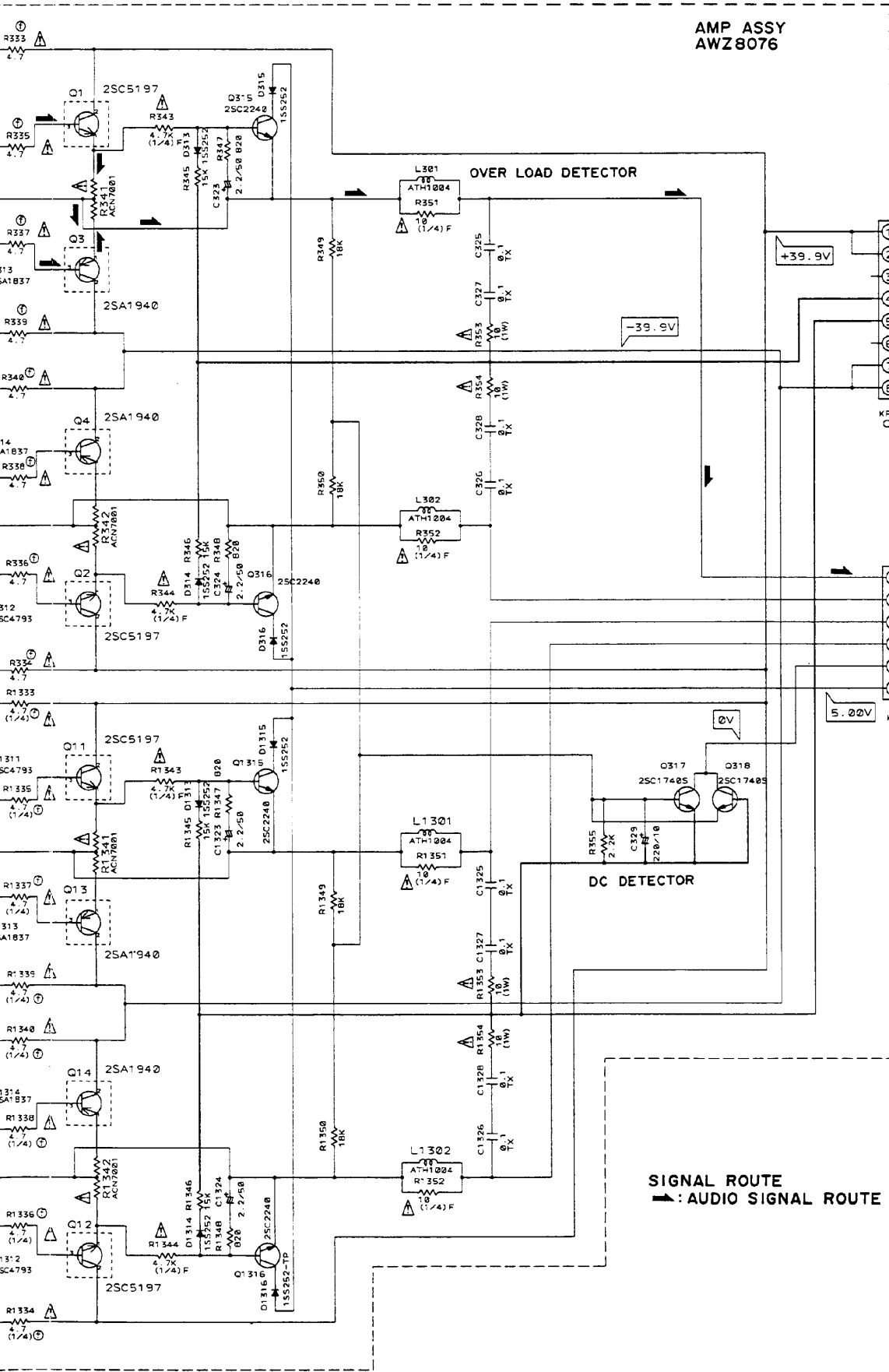

TO MOTHER ASSY (1/3) 407
(SCH-2) (J7)



TO MOTHER ASSY (1/3) 408
(SCH-2) (J8)

SIGNAL ROUTE
 —: AUDIO SIGNAL ROUTE

VSX-505RDS, VSX-405RDS

4.7 AMP ASSY

TO VOL. ASSY 602 (JIS)
(SCH-8)
GND
GND
GND

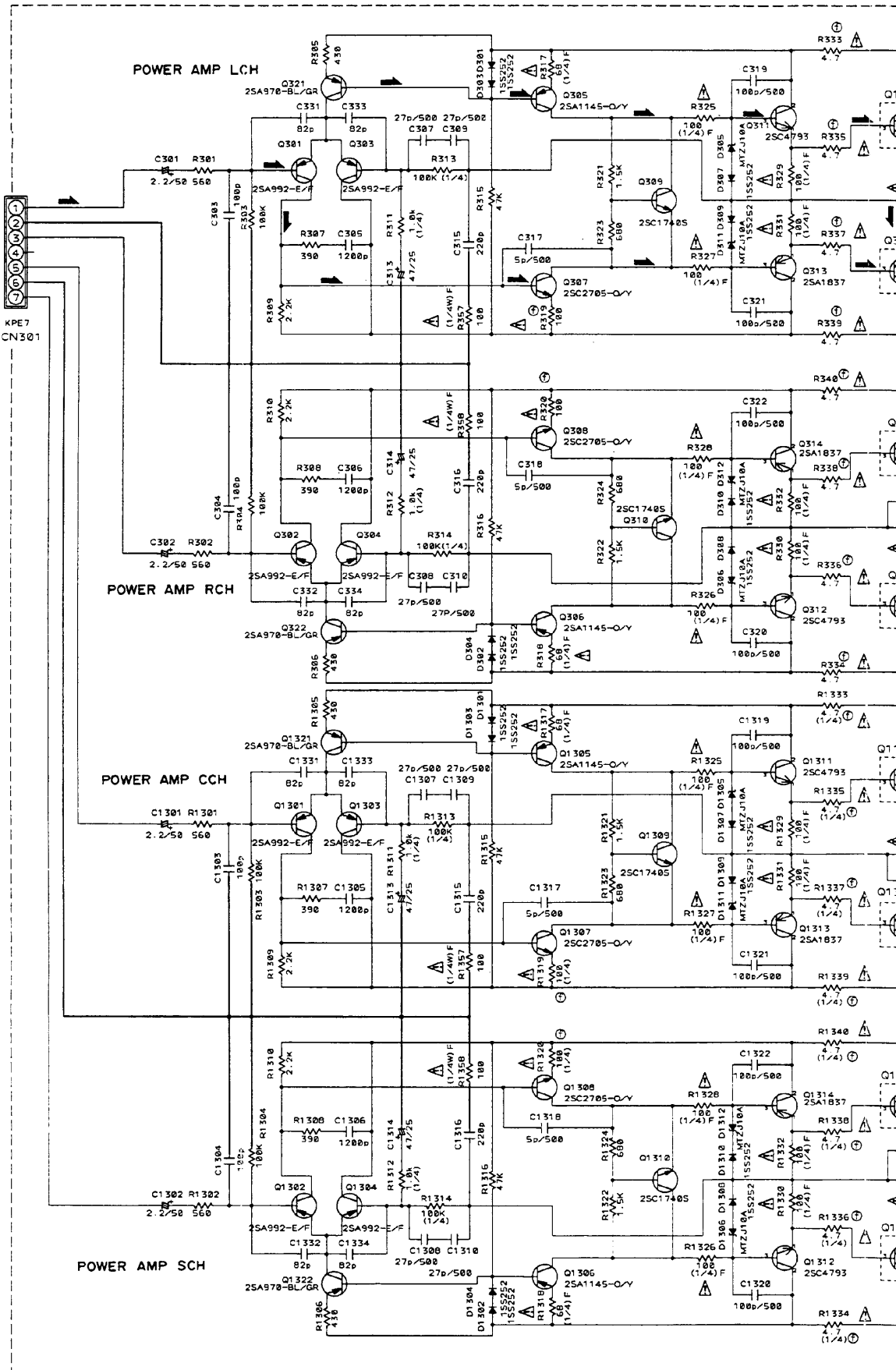

SCH-7

AMP ASSY

• This diagram is viewed from the mounted parts side.

VSX-505RDS, VSX-405RDS

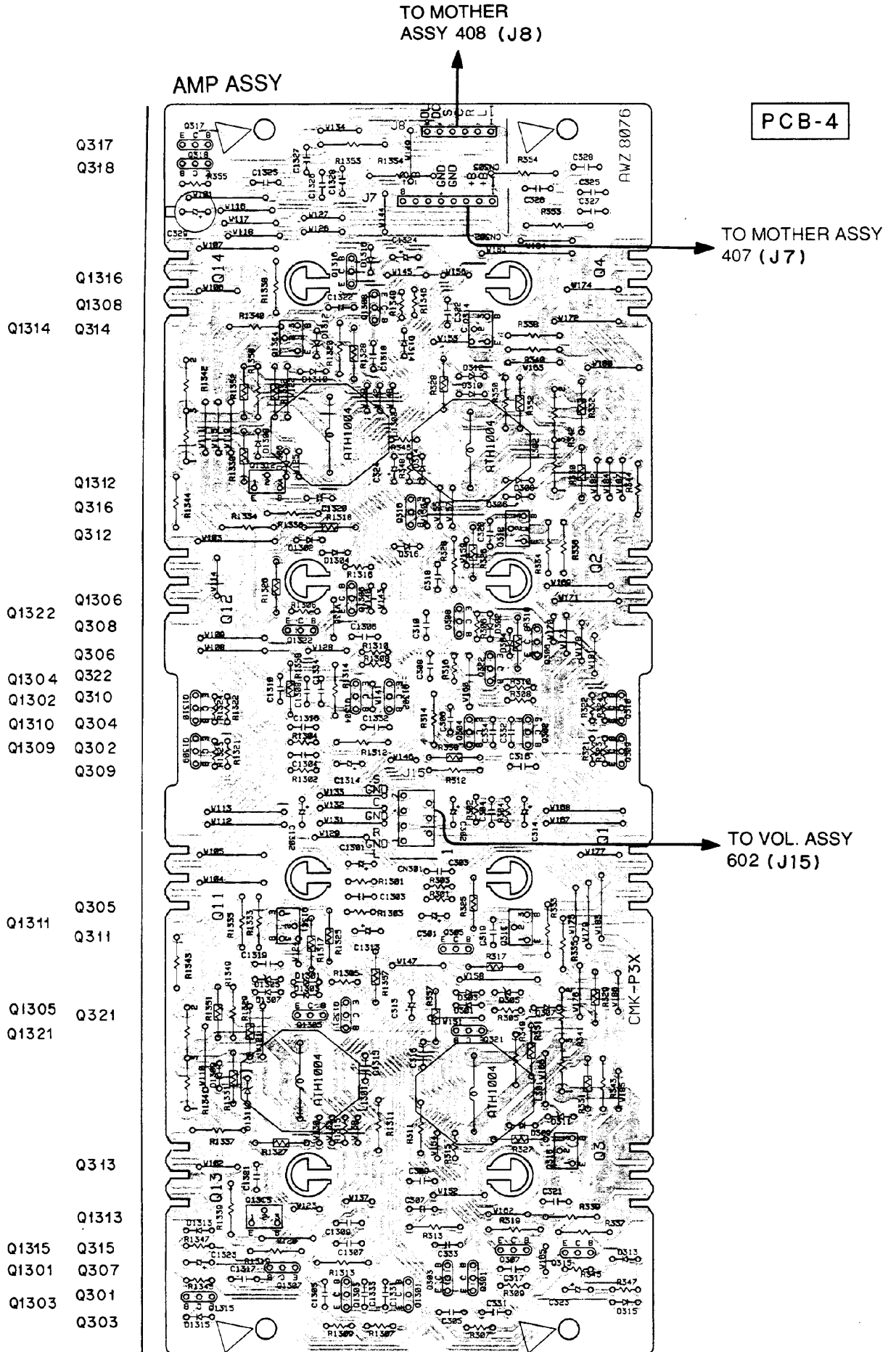

VSX-505RDS, VSX-405RDS

4.8 VOL. ASSY AND FRONT SP. ASSY

- This diagram is viewed from the mounted parts side.

- The parts mounted on this PCB include all necessary parts for several destinations. For further information for respective destinations, be sure to check with the schematic diagram.

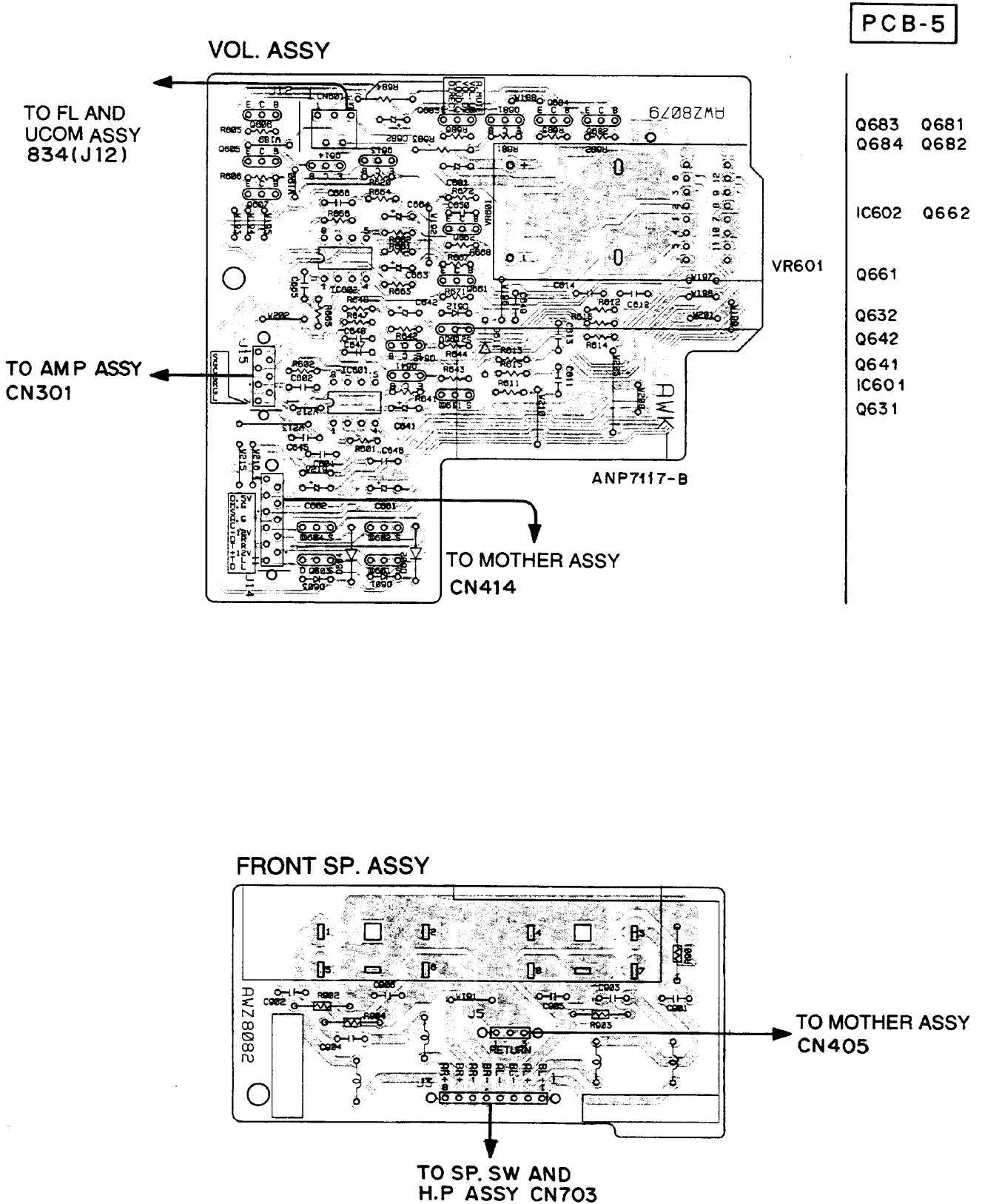

VOL. ASSY
AWZ8079

DIRECT

TO MOTHER ASSY (1/3)
CN414 (SCH-2)

- 1 DIRECT L
- 2 TONE L
- 3 +12V
- 4 TONE R
- 5 DIRECT R
- 6 -12V
- 7 CENTER
- 8 A. GND
- 9 REAR
- 10 M. GND
- 11 D. 5V

D15A11-150-2651
J14

AKT1007

(J14)

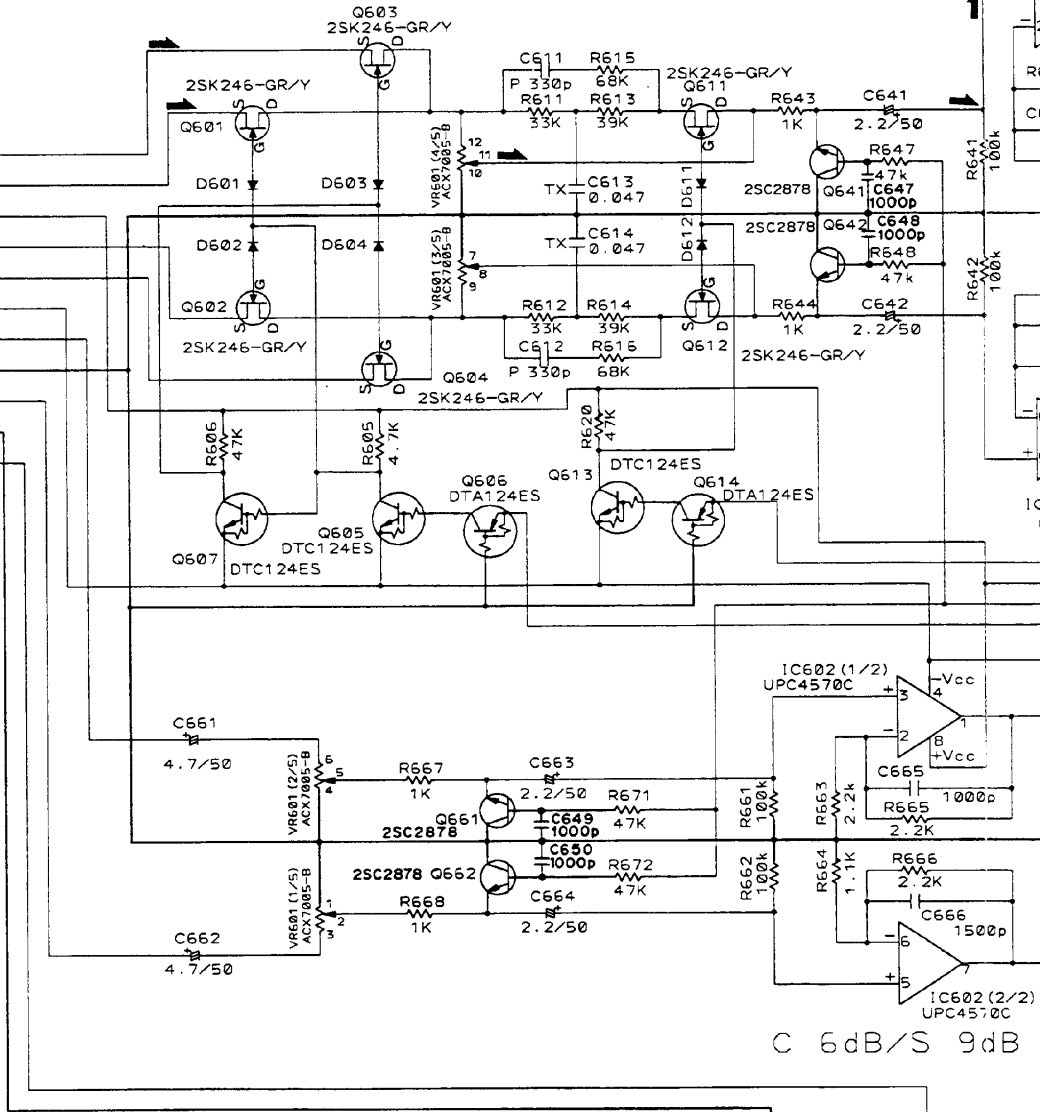

C 6dB/S 9dB

MOTOR DRIVER

SCH-8

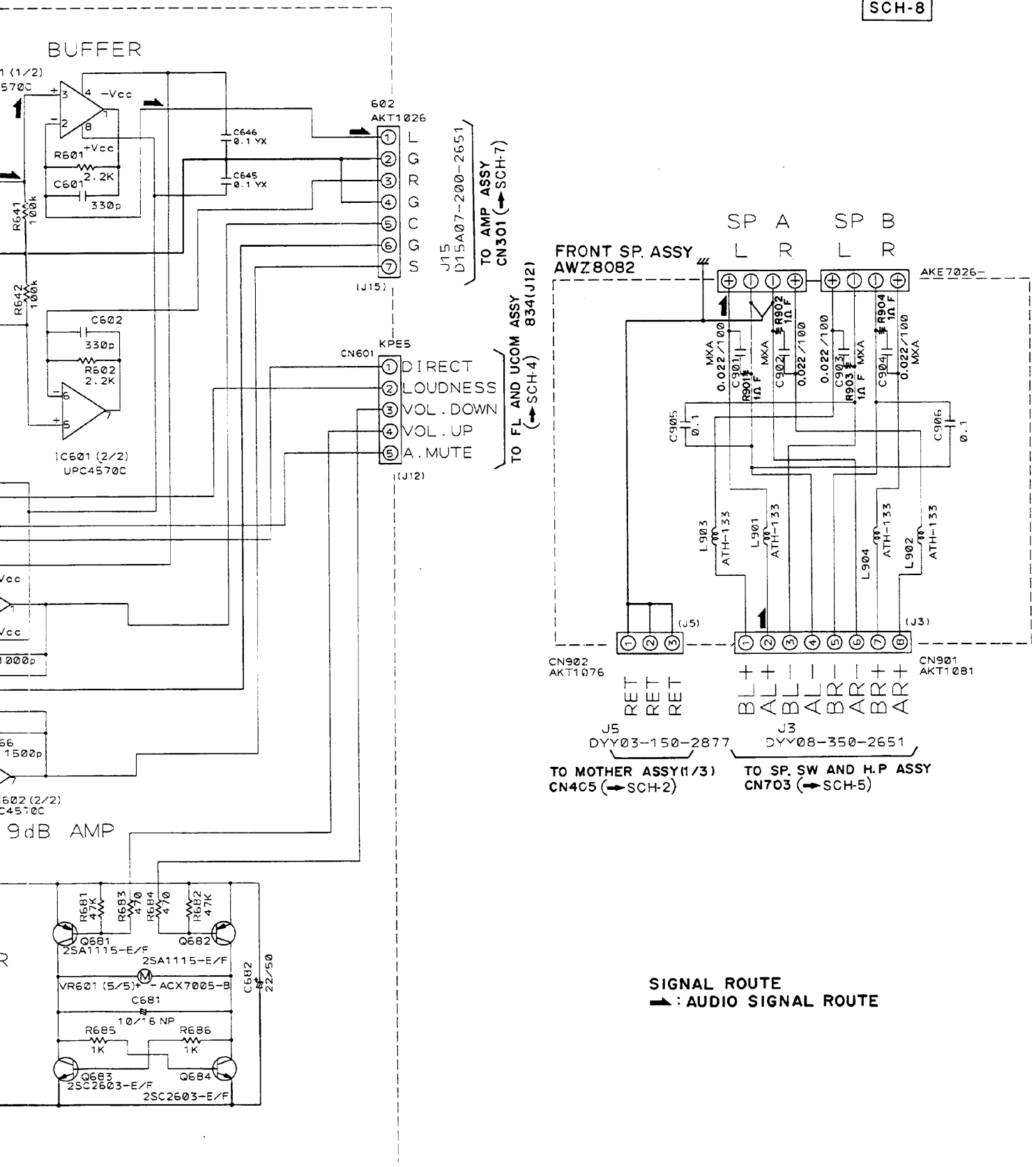

SIGNAL ROUTE
 ─▶ : AUDIO SIGNAL ROUTE

VOL. ASSY,
 FRONT SP. ASSY

SCH-8

VSX-505RDS, VSX-405RDS

5. PCB PARTS LIST

NOTES:

- Parts marked by "NSP" are generally unavailable because they are not in our Master Spare Parts List.
- The Δ mark found on some component parts indicates the importance of the safety factor of the part. Therefore, when replacing, be sure to use parts of identical designation.
- Parts marked by "⊙" are not always kept in stock. Their delivery time may be longer than usual or they may be unavailable.
- When ordering resistors, first convert resistance values into code form as shown in the following examples.

Ex.1 When there are 2 effective digits (any digit apart from 0), such as 560 ohm and 47K ohm (tolerance is shown by J=5%, and K=10%).

560 Ω \rightarrow $56 \times 10^1 \rightarrow 561$ RD1/4PU $\boxed{561} J$

47 k Ω \rightarrow $47 \times 10^3 \rightarrow 473$ RD1/4PU $\boxed{473} J$

0.5 Ω \rightarrow 0R5RN2H $\boxed{0R5} K$

1 Ω \rightarrow 1R0RS1P $\boxed{1R0} K$

Ex.2 When there are 3 effective digits (such as in high precision metal film resistors).

5.62 k Ω \rightarrow $562 \times 10^1 \rightarrow 5621$ RN1/4PC $\boxed{5621} F$

■ LIST OF WHOLE PCB ASSEMBLIES

Mark	PCB Assemblies	Part No.						Remarks
		VSX-505RDS			VSX-405RDS			
		HVXK	HYXK/EW	HYXK/GR	HVXK	HYXJ/EW	HYXK/GR	
NSP	MAIN ASSY	AWK7235	AWK7235	AWK7235	AWK7233	AWK7233	AWK7233	
	└ MOTHER ASSY	AWZ8057	AWZ8057	AWZ8057	AWZ8058	AWZ8058	AWZ8058	
	└└ 4 CHAIN F.E MODULE	AXQ1004	AXQ1004	AXQ1004	AXQ1004	AXQ1004	AXQ1004	
	└ FL AND UCOM ASSY	AWZ8062	AWZ8062	AWZ8062	AWZ8062	AWZ8062	AWZ8062	
	└ ST. IND. ASSY	AWZ8065	AWZ8065	AWZ8065	AWZ8065	AWZ8065	AWZ8065	
	└ VIDEO ASSY	AWZ8066	AWZ8066	AWZ8066	Not Used	Not Used	Not Used	
	└ REG ASSY	AWZ8067	AWZ8067	AWZ8067	AWZ8067	AWZ8067	AWZ8067	
	└ SP. SW AND H.P ASSY	AWZ8070	AWZ8070	AWZ8070	AWZ8070	AWZ8070	AWZ8070	
NSP	└ TRANS ASSY	AWZ8073	AWZ8073	AWZ8073	AWZ8073	AWZ8073	AWZ8073	
NSP	AMP AND VOL. ASSY	AWK7236	AWK7236	AWK7236	AWK7236	AWK7236	AWK7236	
	└ AMP ASSY	AWZ8076	AWZ8076	AWZ8076	AWZ8076	AWZ8076	AWZ8076	
	└ VOL. ASSY	AWZ8079	AWZ8079	AWZ8079	AWZ8079	AWZ8079	AWZ8079	
	└ FRONT SP. ASSY	AWZ8082	AWZ8082	AWZ8082	AWZ8082	AWZ8082	AWZ8082	

■ CONTRAST OF PCB ASSEMBLIES

MOTHER ASSY

Although AWZ8057 and AWZ8058 are different in part number, they have the same service parts.

■ PARTS LIST FOR VSX-505RDS

Mark	No.	Description	Part No.	Mark	No.	Description	Part No.
MOTHER ASSY							
					Q151, Q191, Q192		2SA933S
					Q409		2SA965
SEMICONDUCTORS							
					Q101, Q181, Q403, Q406, Q411		2SC1740S
	IC203		BA4558DX		Q132		2SC1740SLN
	IC151		LA1851N		Q410		2SC2235
	IC131		LM7001J		Q103		2SC2668
	IC1102		NJU9702D		Q131		2SK246
	IC1101		NJW1102FG1				
					Q102		DTA143ES
	IC202		TC9164AN		Q405		DTC124ES
	IC201		UPC4570C		Q401		DTC143ES
	Q104		2SA854S		D409, D410, D416-D419		1SS252

VSX-505RDS, VSX-405RDS

Mark	No.	Description	Part No.
	R157		RD1/6PM113J
	R223, R224		RD1/6PM122J
	R110		RD1/6PM151J
	R111, R113, R156		RD1/6PM152J
	R104, R1106, R1109, R1112, R1115		RD1/6PM153J
	R1122, R1124, R1127		RD1/6PM153J
	R416		RD1/6PM182J
	R105, R108, R135, R141, R181		RD1/6PM221J
	R193, R196		RD1/6PM221J
	R109, R150		RD1/6PM222J
	R1101, R1102, R1113, R151		RD1/6PM223J
	R235, R236, R241, R242		RD1/6PM224J
	R191, R194		RD1/6PM272J
	R1126		RD1/6PM300J
	R231, R232		RD1/6PM303J
	R101		RD1/6PM330J
	R112, R203, R204, R207-R212		RD1/6PM331J
	R154, R410		RD1/6PM332J
	R152		RD1/6PM333J
	R1116		RD1/6PM334J
	R107		RD1/6PM391J
	R153, R166		RD1/6PM392J
	R415		RD1/6PM393J
	R229, R230		RD1/6PM394J
	R1129		RD1/6PM433J
	R116, R1181, R1182, R1184, R1185		RD1/6PM471J
	R233, R234		RD1/6PM471J
	R1011, R114, R134, R182		RD1/6PM472J
	R419-R421		RD1/6PM472J
	R1105, R1108, R185, R405		RD1/6PM473J
	R1103		RD1/6PM475J
	R227, R228		RD1/6PM511J
	R155		RD1/6PM512J
	R413, R414		RD1/6PM513J
	R106, R138-R140, R158		RD1/6PM561J
	R137		RD1/6PM562J
	R1107, R1110		RD1/6PM752J
	R159, R160, R163		RD1/6PM912J
	R164		RD1/6PM913J
	R1111		RN1/6PQ1003F
△	R409		RS2LMF121J
	VR151 (10kΩ/0.1W)		ACP1043
	Other Resistors		RD1/4PU□□□□
OTHERS			
	201	PIN JACK 6P	AKB7013
	202	PIN JACK 4P	AKB7014
	CN203	PIN JACK 4P	AKB7015
	CN434	6P SPEAKER TERMINAL	AKE7020
	H401, H402	FUSE CLIP	AKR1003
	404	3P CABLE HOLDER	AKT1076
	401, 402, 408	6P CABLE HOLDER	AKT1079
	407	8P CABLE HOLDER	AKT1081
	406	9P CABLE HOLDER	AKT1082
	CN414	11P JUMPER CONNECTOR	KPE11
	CN410	14P JUMPER CONNECTOR	KPE14

Mark	No.	Description	Part No.
	CN411	15P JUMPER CONNECTOR	KPE15
	CN413	8P JUMPER CONNECTOR	KPE8
	JA431	REMOTE CONTROL JACK (12V)	PKN1004
	101	ANTENNA TERMINAL	RKE1002
	JA432	1P PIN JACK	VKB1077
	102	EARTH METAL FITTING	VNF-091
	111	AM RF TUNING BLOCK	AXX7024

4 CHAIN F.E MODULE

4 CHAIN F.E MODULE has no service part.

FL AND UCOM ASSY

SEMICONDUCTORS

IC501	BA4558DX
IC826	PDG173A
IC801	SAA6579
Q801	2SA1115
Q501, Q502, Q803	2SC1740S
Q827, Q832	DTA124ES
Q828, Q829	DTA143ES
Q831	DTC124ES
Q802, Q826, Q830	DTC143ES
D827-D831, D836-D839	1SS252
D841, D842	1SS252
D826	AEL1065

COILS AND FILTERS

X826	ASS1055
X801	ASS7004
L827	LAU010J

SWITCHES AND RELAYS

S825-S827, S829-S832	ASG1029
S834-S837, S839-S844	ASG1029

CAPACITORS

C828	ACH1246
C803	CCCCH470J50
C804	CCCCH820J50
C503, C504	CCCSL151J50
C835	CCCSL471J50
C807	CEAS010M50
C511, C512	CEAS0R1M50
C505, C506	CEAS100M50
C802, C809	CEAS101M25
C827	CEAS221M16
C806, C831	CEAS2R2M50
C509, C510	CEASR47M50
C507, C508	CFTXA153J50
C832, C845	CGCYX104M16
C805	CKCYB561K50
C501, C502, C851	CKCYF103Z50
C852	CKCYF223Z50
C846	CKCYF473Z50
C847-C850	CKPUYB102K50
C836, C837	CKPUYF473Z50

VSX-505RDS, VSX-405RDS

Mark	No.	Description	Part No.
	C840		CKPUYX222M16
	C801, C808, C826, C830, C833		CKPUYY103M16
	C829		CKPYF103Z50

RESISTORS

R511, R512	RD1/6PM101J
R806, R807, R845, R853	RD1/6PM102J
R517, R518, R847, R848	RD1/6PM103J
R805, R837-R841, R854, R855	RD1/6PM104J
R802, R803	RD1/6PM222J
R503, R504	RD1/6PM224J
R505-R508	RD1/6PM272J
R830	RD1/6PM331J
R519, R520	RD1/6PM332J
R804	RD1/6PM333J
R513, R514	RD1/6PM471J
R831	RD1/6PM472J
R801, R827, R828	RD1/6PM473J
R849	RD1/6PM4R7J
R856	RD1/6PM681J
R509, R510	RD1/6PM821J
R515, R516	RD1/6PM823J
VR503 (500kΩ)	ACS7004
VR501, VR502 (30kΩ)	ACS7005
Other Resistors	RD1/4PU□□□□

OTHERS

V801	FL INDICATOR TUBE	AAV7026
834	CABLE HOLDER	AKT1012

ST. IND. ASSY

SEMICONDUCTORS

D876	BR3371XJ30A
------	-------------

SWITCHES AND RELAYS

S876-S878	ASG1029
-----------	---------

RESISTORS

All Resistors	RD1/6PM□□□□
---------------	-------------

VIDEO ASSY

SEMICONDUCTORS

IC1501	LA7952
Q1501, Q1502	2SC1740S

CAPACITORS

C1505, C1507	CEAS101M25
C1503, C1504	CEAS471M6
C1501, C1502	CEAS4R7M50
C1506, C1508	CGCYX473M16
C1509, C1510	CKCYF103Z50

RESISTORS

R1507	RD1/2PM271J
Other Resistors	RD1/6PM□□□□

Mark	No.	Description	Part No.
OTHERS			
	1501	2P PIN JACK	AKB7016
	1502	2P PIN JACK	AKB7017
	CN1503	4P JUMPER CONNECTOR	KPE4

REG ASSY

SEMICONDUCTORS

IC476	NJM78M12FA
IC475	NJM78M56FA
IC477	NJM79M12FA

CAPACITORS

C478, C480	CEAS221M16
C476	CEAS470M25
C475, C477, C479	CKCYF103Z50

RESISTORS

△ R475, R476	RS2LMF391J
--------------	------------

OTHERS

475	9P CABLE HOLDER	AKT1082
-----	-----------------	---------

SP. SW AND H.P ASSY

SWITCHES AND RELAYS

S701, S702	ASG1017
------------	---------

CAPACITORS

C701, C702	CKCYB392K50
------------	-------------

RESISTORS

△ R701, R702	RS1LMF331J
△ R703, R704	RS1LMF681J

OTHERS

CN701	HEADPHONE JACK	AKN7001
701	EARTH METAL FITTING	VNF-091

TRANS ASSY

CAPACITORS

C1401	ACH1237
-------	---------

RESISTORS

△ R1402	RD1/4PMFL4R7J
△ R1401	RFA1/4PS4R7J
Other Resistors	RD1/4PM□□□□

OTHERS

H1401-H1404	FUSE CLIP	AKR1003
951, 952	6P CABLE HOLDER	AKT1079

AMP ASSY

SEMICONDUCTORS

Q1305, Q1306, Q305, Q306	2SA1145
--------------------------	---------

VSX-505RDS, VSX-405RDS

Mark	No.	Description	Part No.
	Q1313, Q1314, Q313, Q314		2SA1837
	Q1321, Q1322, Q321, Q322		2SA970
	Q1301-Q1304, Q301-Q304		2SA992
	Q1309, Q1310, Q309, Q310		2SC1740S
	Q317, Q318		2SC1740S
	Q1315, Q1316, Q315, Q316		2SC2240
	Q1307, Q1308, Q307, Q308		2SC2705
	Q1311, Q1312, Q311, Q312		2SC4793
	D1301-D1304, D1307-D1310		1SS252
	D1313-D1316, D301-D304		1SS252
	D307-D310, D313-D316		1SS252
	D1305, D1306, D1311, D1312		MTZJ10A
	D305, D306, D311, D312		MTZJ10A

COILS AND FILTERS

L1301, L1302, L301, L302	ATH1004
--------------------------	---------

CAPACITORS

C1317, C1318, C317, C318	CCCSL050C500
C1303, C1304, C303, C304	CCCSL101J50
C1319-C1322, C319-C322	CCCSL101K500
C1315, C1316, C315, C316	CCCSL221J50
C1307-C1310, C307-C310	CCCSL270K500

C1331-C1334, C331-C334	CCCSL820J50
C329	CEAS221M16
C1301, C1302, C1323, C1324	CEAS2R2M50
C301, C302, C323, C324	CEAS2R2M50
C1313, C1314, C313, C314	CEAS470M25

C1325-C1328, C325-C328	CFTXA104J50
C1305, C1306, C305, C306	CKCYB122K50

RESISTORS

△ R1341, R1342, R341, R342 (0.33kΩ5W)	ACN7001
R1311, R1312, R311, R312	RD1/4PM102J
R1313, R1314, R313, R314	RD1/4PM104J
△ R1343, R1344, R343, R344	RD1/4PMF472J
△ R1351, R1352, R351, R352	RD1/4PMFL100J
△ R1325-R1332, R1357, R1358	RD1/4PMFL101J
△ R325-R332, R357, R358	RD1/4PMFL101J
△ R1317, R1318, R317, R318	RD1/4PMFL680J
R1303, R1304, R303, R304	RD1/6PM104J
R1321, R1322, R321, R322	RD1/6PM152J
R1345, R1346, R345, R346	RD1/6PM153J
R1349, R1350, R349, R350	RD1/6PM183J
R1309, R1310, R309, R310, R355	RD1/6PM222J
R1307, R1308, R307, R308	RD1/6PM391J
R1305, R1306, R305, R306	RD1/6PM431J
R1301, R1302, R301, R302	RD1/6PM561J
R1323, R1324, R323, R324	RD1/6PM681J
R1347, R1348, R347, R348	RD1/6PM821J
△ R1319, R1320, R319, R320	RFA1/4PS101J
△ R1333-R1340, R333-R340	RFA1/4PS4R7J
△ R1353, R1354, R353, R354	RS1LMF100J
Other Resistors	RD1/4PU□□□□

OTHERS

CN301	7P JUMPER CONNECTOR	KPE7
-------	---------------------	------

VOL. ASSY

SEMICONDUCTORS

IC601, IC602	UPC4570C
Q681, Q682	2SA1115
Q683, Q684	2SC2603
Q641, Q642, Q661, Q662	2SC2878
Q601-Q604, Q611, Q612	2SK246
Q606, Q614	DTA124ES
Q605, Q607, Q613	DTC124ES
D601-D604, D611, D612	1SS252

CAPACITORS

C681	CEANP100M16
C682	CEAS220M50
C641, C642, C663, C664	CEAS2R2M50
C661, C662	CEAS4R7M50
C613, C614	CFTXA473J50
C645, C646	CGCYX104M16
C665	CKCYB102K50
C666	CKCYB152K50
C601, C602	CKCYB331K50
C647-C650	CKPUYB102K50
C611, C612	CQPA331J100

RESISTORS

VR601 (100kΩ)	ACX7005
Other Resistors	RD1/6PM□□□□

OTHERS

601	CABLE HOLDER	AKT1007
CN601	5P JUMPER CONNECTOR	KPE5

FRONT SP. ASSY

COILS AND FILTERS

L901-L904	ATH-133
-----------	---------

CAPACITORS

C905, C906	CGCYX104M25
C901-C904	CQMXA223J100

RESISTORS

R901-R904	RD1/4PMFL010J
-----------	---------------

OTHERS

1901	8P SPEAKER TERMINAL	AKE7026
902	3P CABLE HOLDER	AKT1076
901	8P CABLE HOLDER	AKT1081

VSX-505RDS, VSX-405RDS

6. ADJUSTMENTS

ADJUSTMENT OF FM TUNER SECTION

- Set the FM/AM selector to FM BAND.
- Connect the wiring as shown in Fig. 1-1.

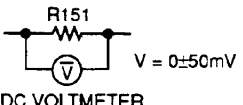
Step No.	Adjustment Title	FM SG (1kHz, ± 75 kHz dev.)		Reception Frequency Display	Adjustment Location	Specifications
		Frequency (MHz)	Level (dB μ V)			
1	Center Adjustment	98	60	98.0 MHz	L151	Adjust so that the DC voltage of R151's both ends becomes $0V \pm 50mV$.  DC VOLTMETER
2	Front-end Sensitivity Check	98	Less than 14	98.0 MHz	—	Less than 14 dB μ V.
3	Stereo Separation Check	89	60	89.0 MHz	—	Less than 23 dB. In case out of standard, cut the R157.
4	TUNED IND. Lighting Level	98	18 (± 3 dB)	98.0 MHz	VR151	18 dB μ V ± 3 dB. Adjust so that the indicator of TUNED IND. starts to light up.

Note:

- Make indicator adjustments in order of AM \rightarrow FM.

ADJUSTMENT OF MW TUNER SECTION

- Set the FM/AM selector to AM (MW) BAND.
- Connect the wiring as shown in Fig. 1-1.

Step No.	Adjustment Title	AM SG (400Hz, 30% Mod.)		Reception Frequency Display	Adjustment Location	Specifications
		Frequency (kHz)	Level (dB μ V/m)			
1	TUNED IND. Lighting Level Check	999*1	Less than 65	999 kHz*1	—	Less than 65 dB μ V/m. In case out of standard, cut the R164.

*1: For the area using 10 kHz step, frequencies should be 1000 kHz.

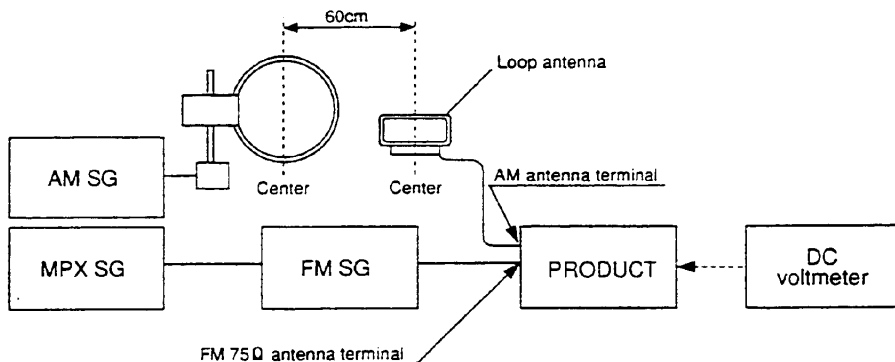

Fig. 1-1. AM and FM Adjustment Wiring Diagram

VSX-505RDS, VSX-405RDS

MOTHER ASSY

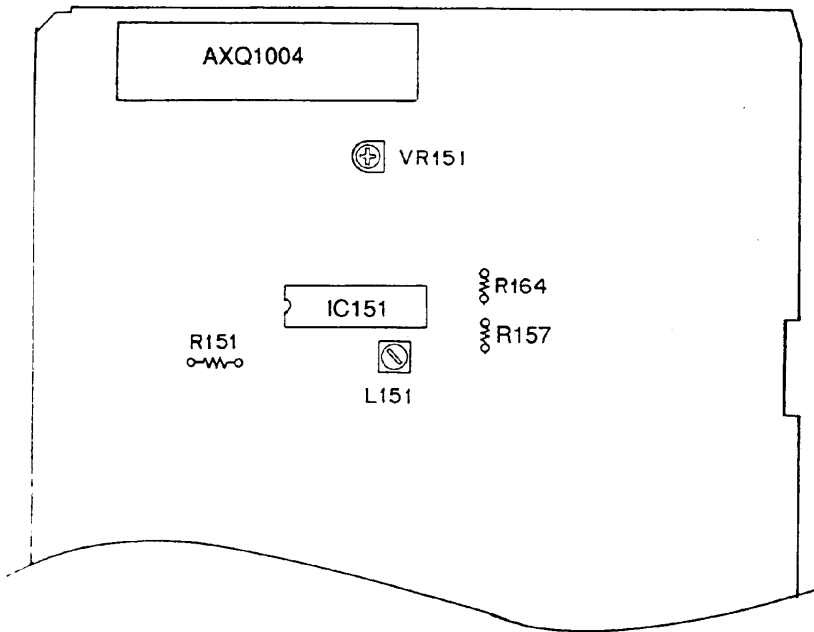

Fig. 1-2. Adjustment Points

VSX-505RDS, VSX-405RDS

7. IC INFORMATION

• The information shown in the list is basic information and may not correspond exactly to that shown in the schematic diagrams.

■ NJW1102FG1 (MOTHER ASSY: IC1101)

DOLBY PROLOGIC IC

● Block Diagram

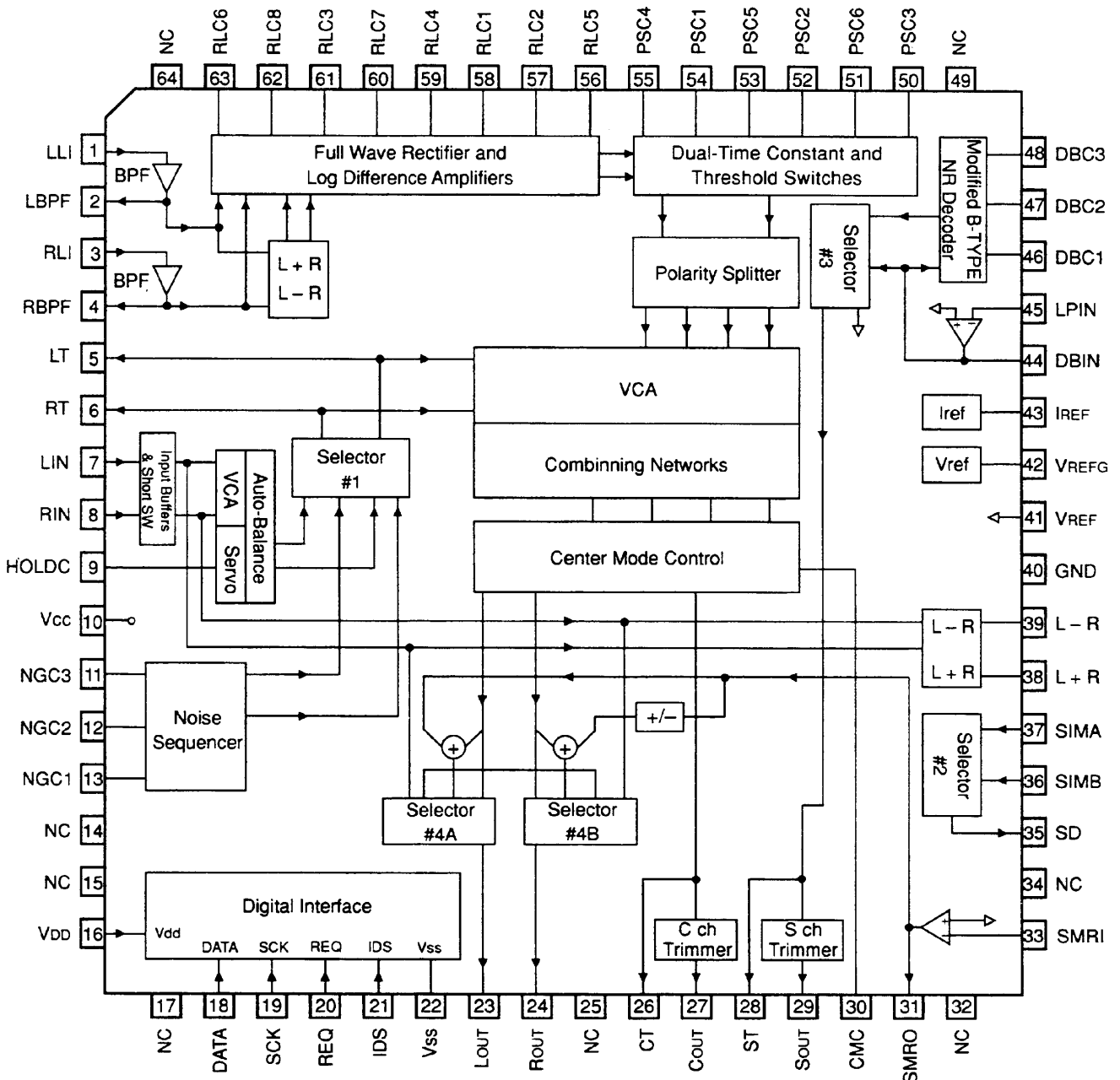

■ NJU9702D (MOTHER ASSY: IC1102) DIGITAL DELAY IC

● Pin Arrangement (Top View)

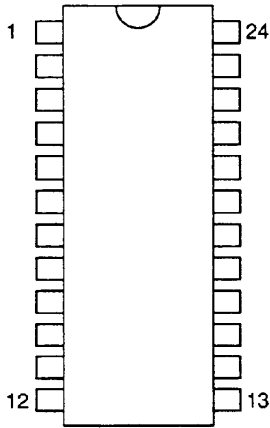

● Block Diagram

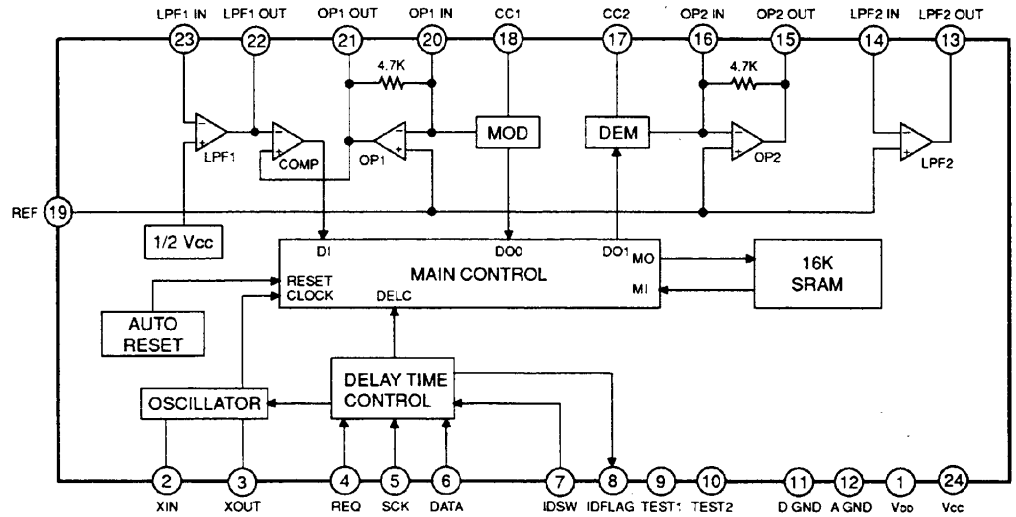

● Pin Function

Pin No.	Abbreviation	Pin Name	I/O	Function
1	V _{DD}	Digital power supply	-	
2	XIN	Oscillator input	I	Connected to a 2 MHz ceramic oscillator.
3	XOUT	Oscillator output	O	Input to Pin ② when the external clock is used.
4	REQ	Request	I	Data request input
5	SCK	Shift clock	I	Serial data shift clock input
6	DATA	Data	I	Serial data input
7	IDSW	ID switch	I	External input pin for the 4th bit of ID code
8	IDFLAG	ID flag	O	Outputs a data input identification pulse and serial data.
9	TEST1	Test 1	-	L = Normal mode
10	TEST2	Test 2	-	L = Normal mode
11	D GND	Digital GND	-	
12	A GND	Analog GND	-	
13	LPF2 OUT	Low-pass filter 2 output	O	Forms the output side low-pass filter with external CR.
14	LPF2 IN	Low-pass filter 2 input	I	
15	OP2 OUT	Operation amplifier 2 output	O	Forms the demodulation integrator with external C.
16	OP2 IN	Operation amplifier 2 input	I	
17	CC2	Current control 2	-	Demodulator ADM control
18	CC1	Current control 1	-	Modulator ADM control
19	REF	Reference	-	Analog reference voltage = 1/2 V _{CC}
20	OP1 IN	Operation amplifier 1 input	I	Forms the modulation integrator with external CR.
21	OP1 OUT	Operation amplifier 1 output	O	
22	LPF1 OUT	Low-pass filter 1 output	O	Forms the input side low-pass filter with external CR.
23	LPF1 IN	Low-pass filter 1 input	I	
24	V _{CC}	Analog power supply	-	

VSX-505RDS, VSX-405RDS

8. FL INFORMATION

■ AAV7026 (FL AND UCOM ASSY: V801)

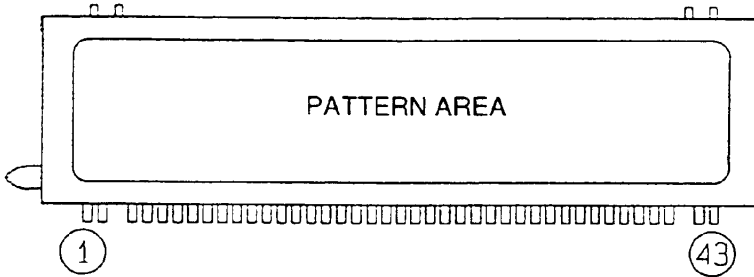

● Pin Assignment

Pin No.	1	2	3	4	5	6	7	8	9	10	11	12	13	14	15	16	17	18	19	20	21	22
Assignment	F1	F1	F1	F1	G2	G3	G4	G5	G6	G7	G8	G9	G10	NL	NL	NL	NL	NL	NL	S21	S16	S17
Pin No.	23	24	25	26	27	28	29	30	31	32	33	34	35	36	37	38	39	40	41	42	43	
Assignment	S15	S15	S15	S15	S10	S9	S8	S7	S6	S5	S3	S4	S2	S1	S18	S19	S20	NP	F2	NL		

F1, F2: Filament S1~S21: Anode NL: No Lead NP: No Pin

● Grid Assignment

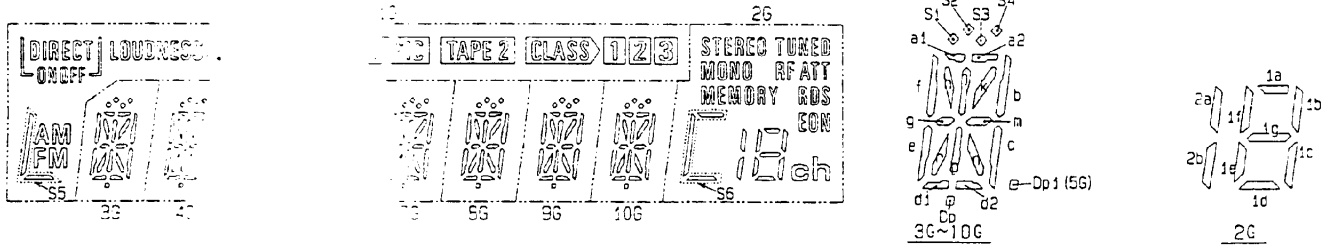

● Anode Assignment

	1G	3G, 4G, 6G~10G	5G
S1	S5	a1	a1
S2	FM	a2	a2
S3	AM	h	h
S4	DIRECT	j	j
S5	ON	k	k
S6	OFF	b	b
S7	PRO LOG	f	f
S8	SFC	m	m
S9	LOUDNESS	g	g
S10	S. BASS	c	c
S11	TAPE 2	e	e
S12	CLASS	r	r
S13	[]	p	p
S14	[2]	n	n
S15	[3]	d1	d1
S16		d2	d2
S17		Dp	Dp
S18		S1, S3	S1, S3
S19		S4	S4
S20		S2	S2
S21		Dp1	Dp1

9. REMOTE CONTROL UNIT [CU-VSX106 (AXD7087)] (VSX-505RDS ONLY)

9.1 EXPLODED VIEW AND PARTS LIST

NOTES:

- Parts marked by "NSP" are generally unavailable because they are not in our Master Spare Parts List.
- The Δ mark found on some component parts indicates the importance of the safety factor of the parts. Therefore, when replacing, be sure to use parts of identical designation.
- Parts marked by "⊙" are not always kept in stock. Their delivery time may be longer than usual or they may be unavailable.

Parts List

Mark	No.	Description	Part No.
	1	Filter	AZA7152
	2	Name plate	AZA7156
	3	Rubber sheet (A)	AZA7154
	4	Rubber sheet (B)	AZA7157
	5	Spring (+)	AZB7049
	6	Spring (-)	AZB7050
	7	Spring	AZB7051
	8	Screw	AZB7052
	9	Remo-con case (A)	AZN7333
	10	Remo-con case (B)	AZN7326
	11	Battery cover	AZN7327
	12	Main key (FF)	AZN7334
	13	Main key (STOP)	AZN7329
	14	Main key (REV)	AZN7335
	15	Main key (PAUSE)	AZN7331
	16	Main key (PLAY)	AZN7336
NSP	17	PCB	AZW7189

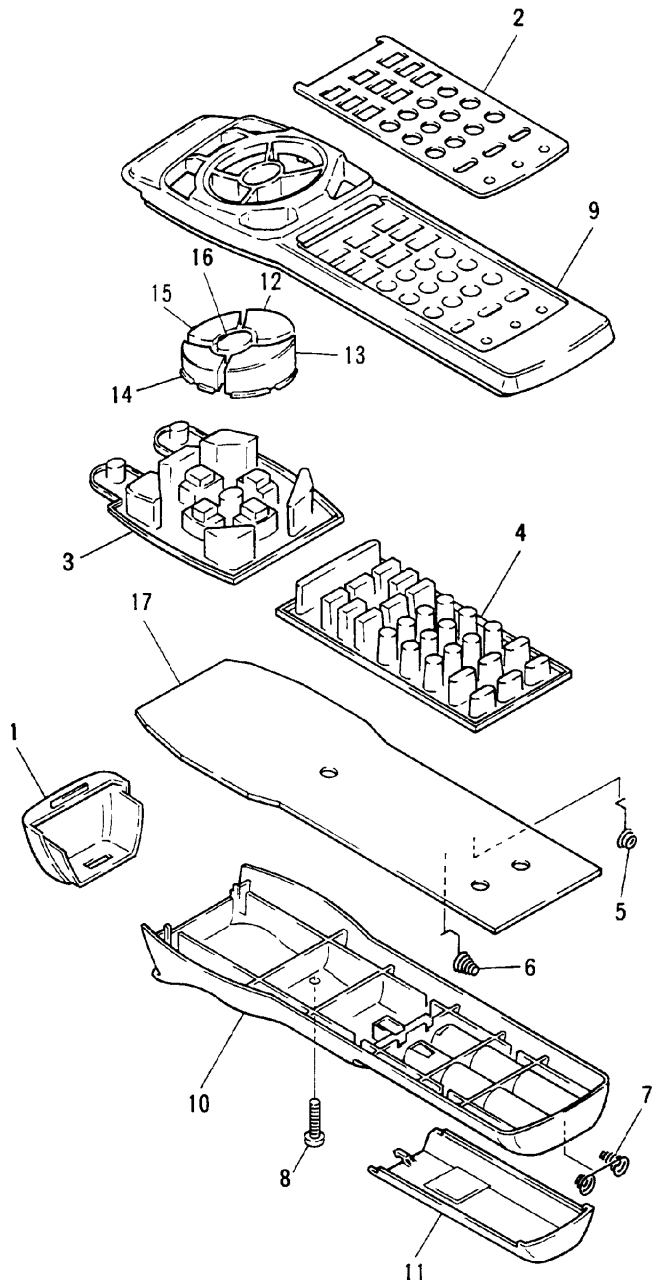

VSX-505RDS, VSX-405RDS

9.2 PCB PARTS LIST

NOTES:

- Parts marked by "NSP" are generally unavailable because they are not in our Master Spare Parts List.
- The Δ mark found on some component parts indicates the importance of the safety factor of the part. Therefore, when replacing, be sure to use parts of identical designation.
- Parts marked by "⊙" are not always kept in stock. Their delivery time may be longer than usual or they may be unavailable.
- When ordering resistors, first convert resistance values into code form as shown in the following examples.

Ex.1 When there are 2 effective digits (any digit apart from 0), such as 560 ohm and 47K ohm (tolerance is shown by J=5%, and K=10%).

560 Ω \rightarrow $56 \times 10^1 \rightarrow 561$ RD1/4PU $\boxed{5}\boxed{6}\boxed{1}$ J
 47 k Ω \rightarrow $47 \times 10^3 \rightarrow 473$ RD1/4PU $\boxed{4}\boxed{7}\boxed{3}$ J
 0.5 Ω \rightarrow 0R5RN2H $\boxed{0}\boxed{R}\boxed{5}$ K
 1 Ω \rightarrow 1R0RS1P $\boxed{1}\boxed{R}\boxed{0}$ K

Ex.2 When there are 3 effective digits (such as in high precision metal film resistors).

5.62 k Ω \rightarrow $562 \times 10^1 \rightarrow 5621$ RN1/4PC $\boxed{5}\boxed{6}\boxed{2}\boxed{1}$ F

Mark	No.	Description	Part No.
------	-----	-------------	----------

SEMICONDUCTORS

IC1 (MC68HC05C9FN)	AZC7112
IC3, IC4	TC74HC07AF
Q2, Q8, Q9	2SA1037K
Q3, Q5, Q6	2SC3265
Q7	2SC2712
D1, D19, D20	SE1003-C
D3-D5	1SS181
D6-D17 LED	CL-230SR-CD
D2, D21	RLS-73

CAPACITORS

C1, C5	CEAS470M10
C2, C4	CKSQYB104K25
C3	CEAS221M10

RESISTORS

R37, R50, R51	RD1/4PM3R9J
Other Resistors	RS1/10S□□□J

OTHERS

X1	RESONATOR	FCR4.0MC3
----	-----------	-----------

9.3 SCHEMATIC DIAGRAM

NOTE FOR SCHEMATIC DIAGRAMS (Type 2A)

1. When ordering service parts, be sure to refer to "PARTS LIST of EXPLODED VIEWS" or "PCB PARTS LIST".

2. Since these are basic circuits, some parts of them or the values of some components may be changed for improvement.

3. **RESISTORS:**
 Unit: k:kΩ, M:MΩ, or Ω unless otherwise noted.
 Rated power: 1/4W, 1/6W, 1/8W, 1/10W unless otherwise noted.
 Tolerance: (F): ±1%, (G): ±2%, (K): ±10%, (M): ±20% or ±5% unless otherwise noted.

4. **CAPACITORS:**
 Unit: p:pF or μF unless otherwise noted.
 Ratings: capacitor (μF)/voltage (V) unless otherwise noted.
 Rated voltage: 50V except for electrolytic capacitors.

5. **COILS:**
 Unit: m:mH or μH unless otherwise noted.

6. **VOLTAGE AND CURRENT:**
 or - V : DC voltage (V) at no input signal unless otherwise noted.
 mA or - mA : DC current at no input signal unless otherwise noted.

7. **OTHERS:**
 • or : Adjusting point.
 • : Measurement point.
 • The mark found on some component parts indicates the importance of the safety factor of the parts. Therefore, when replacing, be sure to use parts of identical designation.

8. **SCH-□ ON THE SCHEMATIC DIAGRAM:**
 • SCH-□ indicates the drawing number of the schematic diagram. (SCH stands for schematic diagram.)

9. **SWITCHES** (Underline indicates switch position):

- K01 : RECEIVER POWER
- K02 : TV POWER
- K03 : TV FUNC
- K04 : POWER
- K05 : MODE CHECK
- K06 : FQ+
- K07 : TV VOL-
- K08 : FM/AM
- K09 : TV VOL+
- K10 : FQ-
- K11 : VOLUME-
- K12 : VOLUME+
- K13 : DISC-, CH-/SIDE A
- K14 : DISC+, CH+/SIDE B
- K15 : VCR ONE TOUCH OPERATION
- K16 : CD ONE TOUCH OPERATION
- K17 : TV CONTROL
- K18 : LD/DVD ONE TOUCH OPERATION
- K19 : TUNER OPERATION
- K20 : FUNCTION
- K21 : SURROUND
- K22 : ALL OFF
- K23 : DIRECT
- K24 : 1
- K25 : 2
- K26 : 3
- K27 : 4
- K28 : 5
- K29 : 6
- K30 : 7
- K31 : 8
- K32 : 9
- K33 : 0, 10
- K34 : +10 TV/VCR
- K35 : DISC
- K36 : TAPE 2
- K37 : RETURN
- K38 : MUTING
- K39 : RESET
- K40 : O.T.O. SET UP
- K41 : PRESET RECALL

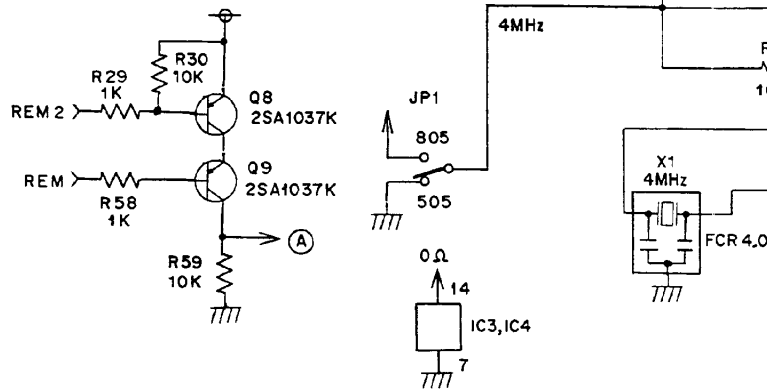
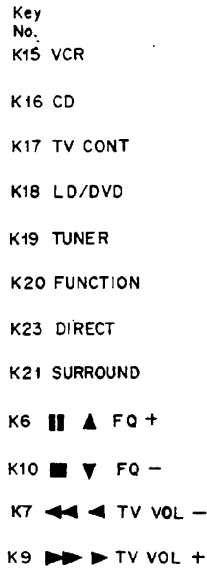
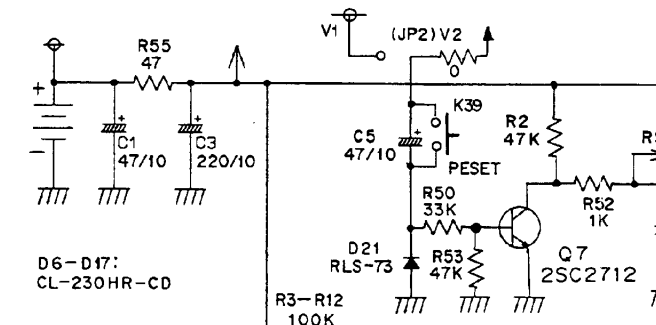

SCH-9

SCHEMATIC DIAGRAM (AXD7087)

SCH-9

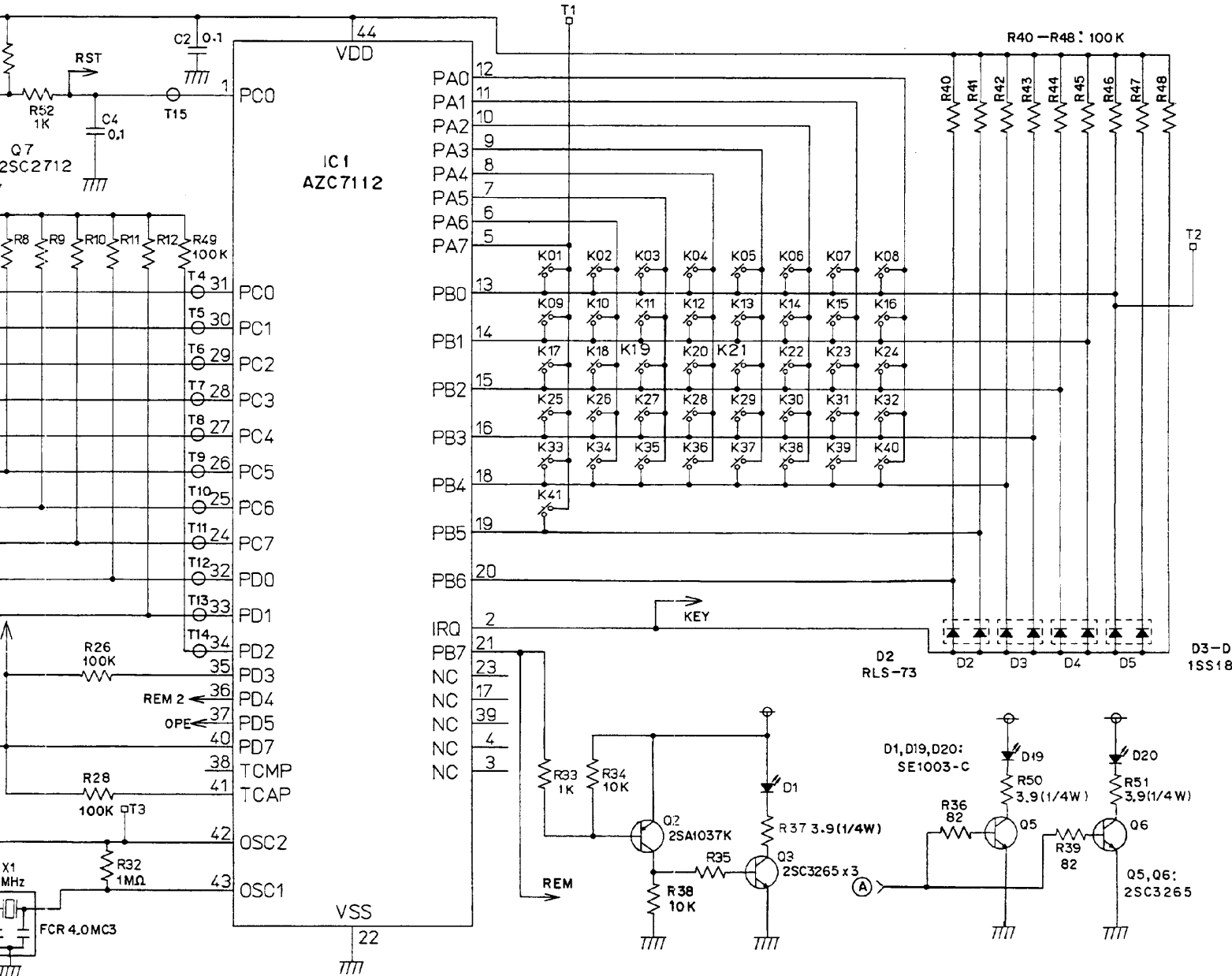

SCHEMATIC DIAGRAM (AXD7087)

SCH-9

10. PANEL FACILITIES

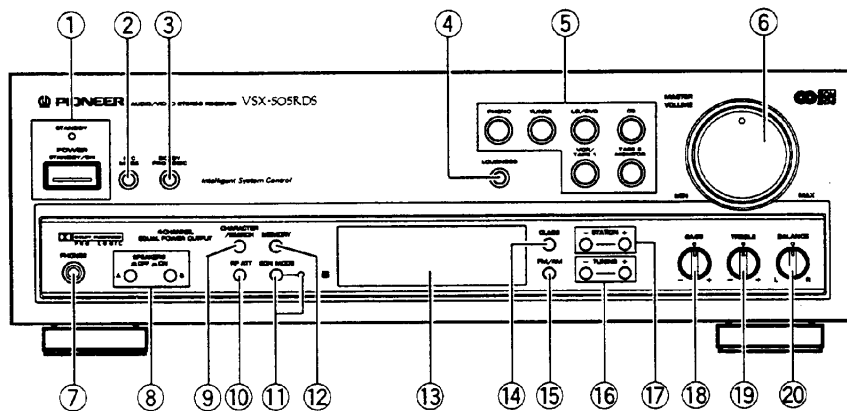

① POWER STANDBY/ON switch, STANDBY indicator

This is the switch for electric power.

ON: When set to the ON position, power is supplied and the unit becomes operational.

STANDBY: When set to the STANDBY position, the main power flow is cut and the unit is no longer fully operational. A minute flow of power feeds the unit to maintain operation readiness.

The STANDBY indicator lights when the power is set to STANDBY, and goes out when set to ON.

(Timer ON/OFF possible)

When the unit is switched ON, ON/OFF control can be performed by means of the optional timer.

NOTE:

When the power is initially turned ON, muting will be applied to prevent sound from being output for about 5 seconds.

② SFC MODE button

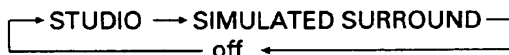

③ DOLBY PRO LOGIC button

Switches DOLBY PRO LOGIC SURROUND on and off.

④ LOUDNESS button

Use when listening at low volume levels.

ON: Boosts low and high frequencies to produce a fuller sense of sound, particularly at low volume levels.

OFF: Normal position.

NOTE:

This button does not operate when the DIRECT button is in the ON position.

⑤ Input selector buttons

PHONO: Press when playing records on a turntable.

TUNER: Press when listening to radio broadcasts.

LD/DVD: Press when performing playback on an LD or DVD player.

CD: Press when playing compact discs on a CD player.

VCR/TAPE 1:

Press when performing playback on a VCR unit or cassette deck.

TAPE 2 MONITOR:

Press when performing playback on a second cassette deck or when monitoring recording.

⑥ MASTER VOLUME control

Use it to simultaneously adjust the sound volume from the front, center, and rear speakers.

⑦ PHONES jack

Connect the plug on your headphones to this jack. Set SPEAKERS A and B switches to OFF if you want to cut the sound from the speakers and listen only through the headphones.

⑧ SPEAKERS (■ OFF, ▬ ON) buttons

These are used to select the speaker through which you wish to listen.

A: When the speakers connected to the A terminals are in use.

B: When the speakers connected to the B terminals are in use.

NOTE:

No sound will be heard through the speakers when both A and B buttons are pressed if only one set of speakers has been connected to either A or B SPEAKERS terminals

⑨ CHARACTER/SEARCH button

When receiving an AM broadcast, or when in the FM RT, FM PS modes:

Press this button; "INPUT" is displayed, and the mode switches to manual station name input.

When in the FM PTY mode:

Press this button; "SEARCH" is displayed, and the mode switches to program type search.

NOTE:

This button does not function in the frequency mode.

⑩ RF ATT button

Set this button to on when receiving strong FM signals (nearby stations) to reduce sound distortion. (RF ATT indicator lights.) Normally, this button should be set off. This button does not affect AM reception.

VSX-505RDS, VSX-405RDS

9.4 PCB CONNECTION DIAGRAM

PCB-6

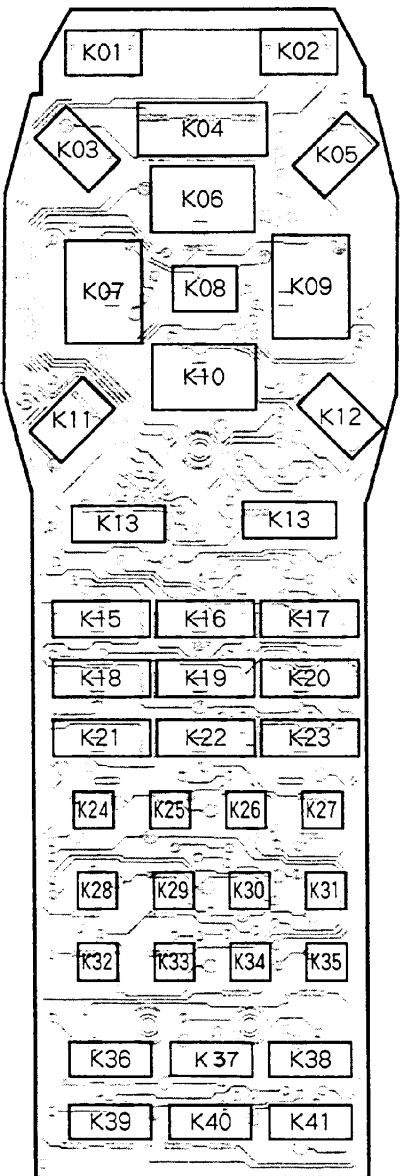
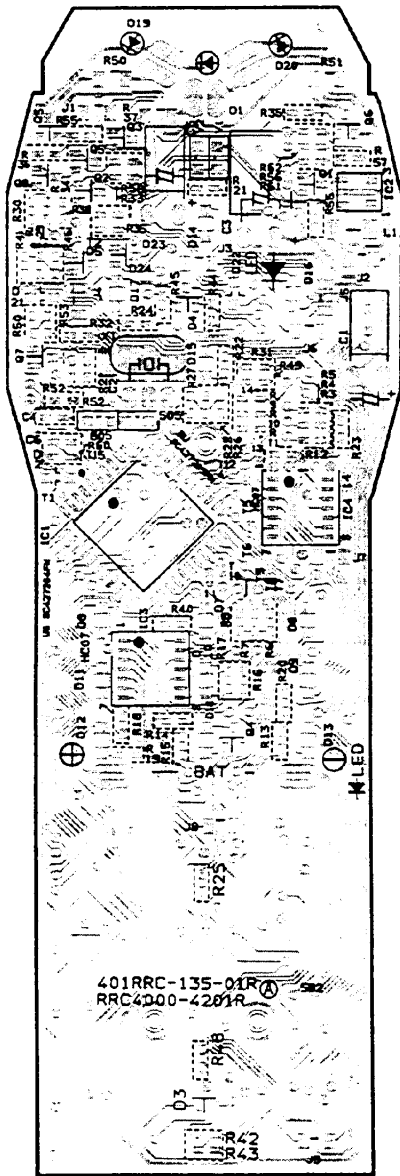

- This diagram is viewed from the mounted parts side.
- This PCB is double sided.

- This diagram is viewed from the foil side.
- This PCB is double sided.

⑪ EON MODE button/indicator

If receiving a station broadcasting EON information, the radio can automatically keep track of broadcast information from other network stations.

If you specify traffic information (TA) or NEWS (PTY) beforehand, the frequency will change automatically when the specified broadcast begins.

The display's EON lights when receiving EON information. When a specified TA or PTY broadcast is received, this indicator flash.

⑫ MEMORY button

Press this button to switch to the frequency preset mode. Used for registering characters when inputting the station name.

Also used for deleting the PI code together with the EON MODE button.

⑬ Display section

⑭ CLASS button

Use to switch between preset memory classes 1 to 3. In each class, one station can be memorized in each of the 1 to 10 stations, enabling a total of 30 stations to be memorized.

⑮ FM/AM button

Use this to switch between FM and AM frequency band reception.

⑯ TUNING -, + buttons

+: The FM or AM band is scanned in the direction of increasing frequency.

Used for selecting characters when inputting the station name and for selecting the program category in PTY search.

-: The opposite operation to that of the UP button takes place.

Used for selecting characters when inputting the station name and for selecting the program category in PTY search.

⑰ STATION -, + buttons

+: Stations change in order in the upward direction.

-: Stations change in order in the downward direction.

⑱ BASS control

Use to adjust the low-frequency level. Turn clockwise to boost bass, and counterclockwise to attenuate bass.

⑲ TREBLE control

Use to adjust the high-frequency level. Turn clockwise to boost treble, and counterclockwise to attenuate treble.

⑳ BALANCE control

Use to adjust the sound volume balance between left and right speakers.

L: Decreases the sound on the right side.

R: Decreases the sound on the left side.

Usually, left and right volume levels should be the same.

DISPLAY SECTION

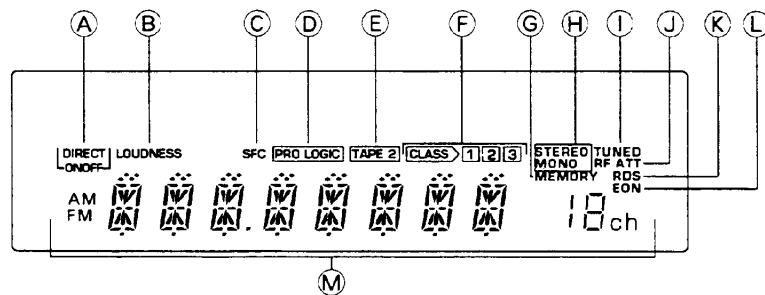

① DIRECT ON/OFF indicator

② LOUDNESS indicator

③ SFC indicator

This lights when an SFC mode (STUDIO, SIMULATED SURROUND) is selected.

④ Dolby PRO LOGIC indicator

⑤ TAPE 2 indicator

Lights up when the input selector is set to TAPE 2 MONITOR ON.

⑥ CLASS 1, 2, 3 indicator

Indicates the class selected by the CLASS button. The current CLASS is displayed.

⑦ MEMORY indicator

⑧ STEREO/MONO indicator

STEREO: Lights up when a stereo FM broadcast is being received.

MONO: Lights up when the FM MONO mode is selected with the MPX button of the remote control unit.

⑨ TUNED indicator

Lights up when a station is tuned.

⑩ RF ATT indicator

Stays lit while RF ATT button is on.

⑪ RDS indicator

Lights when an RDS broadcast is received.

⑫ EON indicator

Lights when a station broadcasting EON information is received.

⑬ Character display

VSX-505RDS, VSX-405RDS

11. SPECIFICATIONS

Amplifier Section

Continuous Power Output (DIN, 2 channels driven)
Front (1kHz, T.H.D. 1%, 4 Ω) 70 W + 70 W
Continuous Power Output (DIN, 4 channels driven)*
Front 50 W + 50 W (1kHz, 1.0%, 4 Ω)
Center 50 W (1kHz, 1.0%, 4 Ω)
Rear 50 W (1kHz, 1.0%, 4 Ω)
Total Harmonic Distortion (both channel driven)*
Front (40 Hz–20,000 Hz, 8 Ω, 40 W OUTPUT) 0.09%

Input (Sensitivity/Impedance)

PHONO MM 2.8 mV/47 kΩ
CD, VCR/TAPE 1, TAPE 2, LD/DVD 200 mV/47 kΩ
Phono Overload Level (T.H.D. 0.1%, 1 kHz)
PHONO MM 100 mV

Frequency Response

PHONO MM 20 Hz to 20,000 Hz ± 0.5 dB
CD, VCR/TAPE 1, TAPE 2, LD/DVD
..... 5 Hz to 100,000 Hz ± 0.5 dB

Output (Level/Impedance)

VCR/TAPE 1 REC, TAPE 2 REC 200 mV/1.0 kΩ
VCR OUT 200 mV/1.0 kΩ

Tone Control

BASS ± 8 dB (100 Hz)
TREBLE ± 8 dB (10 kHz)
LOUDNESS + 6 dB (100 Hz at – 30 dB)
..... + 4 dB (10 kHz at – 30 dB)

Signal-to-Noise Ratio

[DIN (Continuous rated power output/50 mW)]

PHONO MM 68/61 dB
CD, VCR/TAPE 1, TAPE 2, LD/DVD 86/63 dB

* Measured by Audio Spectrum Analyzer.

VIDEO Section

Input (Sensitivity/Impedance)

VCR, LD/DVD 1 Vp-p/75 Ω

Output (Level/Impedance)

VCR REC 1 Vp-p/75 Ω

Frequency Response

VCR, LD/DVD → MONITOR 5 Hz to 10 MHz ± 0.5 dB

Signal-to-Noise Ratio 55 dB

Isolation 55 dB

FM Tuner Section

Frequency Range 87.5 MHz to 108 MHz

Usable Sensitivity Mono:14.2 dBf, IHF (1.4 μ V/75 Ω)

Sensitivity (DIN)

Mono 1.0 μ V/75 Ω

Stereo 50 μ V/75 Ω

Signal-to-Noise Ratio

Mono 77 dB (at 80 dBf)

Stereo 72 dB (at 80 dBf)

Signal-to-Noise Ratio (DIN)

Mono 62 dB

Stereo 58 dB

Distortion Stereo: 0.3 % (1 kHz)

Alternate Channel Selectivity 64 dB (400 kHz)

Stereo Separation 40 dB (1 kHz)

Frequency Response 30 Hz to 15 kHz ± 1 dB

Antenna Input 75 Ω unbalanced

AM Tuner Section

Frequency Range 531 kHz to 1,602 kHz (9 kHz step)

Sensitivity (IHF, Loop antenna) 350 μ V/m

Selectivity 20 dB

Signal-to-Noise Ratio 50 dB

Antenna Loop antenna

Miscellaneous

Power Requirements a.c. 230 Volts, 50/60 Hz

Power Consumption 430 W

In Standby Condition 3W

Dimensions 420 (W) x 140 (H) x 343 (D) mm

Weight (without package) 7.3 kg

Furnished Parts

FM Antenna 1

AM Loop Antenna 1

Dry Cell Batteries (AA/LR6) 2

Remote Control Unit 1

Operating Instructions 1

NOTE:

Specifications and the design are subject to possible modifications without notice, due to improvements.

